

# **SERIES SXL-N**

**PARTS  
AND  
OPERATER  
MANUAL**

**Tandem Disc  
Harrows  
Reversible  
Super Narrow  
Vineyard Disc  
3'8"-7'6"**

**Domries Enterprises, Inc**

**12281 Rd 29**

**Madera, Ca 93638**

**Phone # 559 673-9143 Fax # 559 673-4110**

**VISIT OUR WEB SITE At [domriesentinc.com](http://domriesentinc.com)**

# IMPORTANT! PLEASE READ!

## TO OUR CUSTOMER – USER’S RESPONSIBILITY- WARRANTY

### TO OUR CUSTOMER

The following pages and illustrations are printed to help supply you with the knowledge to better operate and service your new DOMRIES equipment.

We are proud to have you as a customer and feel you will be proud to be a DOMRIES owner.

Any piece of equipment needs and must have a certain amount of service and maintenance to keep it in top running condition. We have attempted to cover all the adjustments required to fit most conditions; however, there may be times special care must be taken to fit a condition.

**Study this operator’s manual carefully and become acquainted with all the adjustments and operating procedures before attempting to operate your new equipment.** Remember, it is a machine and has been designed and tested to do an efficient job in most operating conditions and will perform in relation to the service it receives.

If special attention is required for some conditions, ask your DOMRIES dealer; his Parts and Service Organization will be glad to help and answer any question on operation and service of your new machine.

### ATTENTION! BECOME ALERT!

### YOUR SAFETY IS INVOLVED

This symbol is used to call your attention to safety precautions that should be followed by the operator to avoid accidents. When you see this symbol – Heed Its Warning.

### USER’S RESPONSIBILITY

It is the responsibility of the user to read the Operator’s Manual and understand the safe and correct operating procedures as pertains to the operation of the product, and to lubricate and maintain the product according to the maintenance schedule in the Operator’s Manual.

The user is responsible for inspecting his machine and for having parts repaired or replaced when continued use of the product would cause damage or excessive wear to the other parts. It is the user’s responsibility to deliver his machine to a DOMRIES dealer, for service or replacement of defective parts which are covered by the standard warranty. When requesting warranty service, you present your copy of delivery record.

**MODEL#** \_\_\_\_\_

**SERIAL#** \_\_\_\_\_



## ATTENTION! BECOME ALERT!

### YOUR SAFETY IS INVOLVED!

This Symbol is used to call your attention to safety precautions. That should be followed by the operator to avoid accidents. When you see this – Heed Its Warning.

Many hours of lost time and much suffering is caused by the failure to practice simple safety rules.

1. **READ** this manual carefully to acquaint your – self with the Disk Harrow. Opening unfamiliar equipment can cause accidents.
2. **Lower Implement** if possible, when adjusting maintenance work; otherwise **BLOCKS IT SECURELY** at a workable height.
3. **When Implement** and tractor is parked always lower disk to the ground and place a **FLAG OR OTHER WARNING DEVICE** on each corner as someone could run or bump into the implement.
4. Implement should be **DETACHED ONLY** in an area where Children **DO NOT PLAY**.
5. **DO NOT** wear loose fitting clothing that could catch on various parts.
6. Machinery should be **OPERATED ONLY** by those who are **RESPONSIBLE AND DELEGATED** to do so.
7. **ONLY ONE PERSON** – the operator – should be permitted on the tractor when implement is in operation, he should be thoroughly familiar with tractor and implement.
8. **MAKE CERTAIN** that everyone is clear before starting tractor and implement combination.
9. **BEFORE WORKING** under the any hydraulically controlled unit **MAKE SURE** it is **SECURELY BLOCKED**.
10. **The RATE OF SPEED** on hillsides or curves should be regulated so there is no danger of tipping.
11. **DO NOT** drive too close to the edge of a ditch or creek.
12. **REDUCE SPEED** when transporting unit to avoid bouncing and momentary loss of steer ability.
13. **MAKE CERTAIN** tractor is equipped with sufficient front-end weight to counter-balance the plow weight and maintain stability of front of tractor
14. **DO NOT** attempt to operate tractor and implement unless you are in the driver seat.
15. **ALWAYS** place transmission in **PARK or NEUTRAL, LOCK BRAKES, STOP ENGINE AND REMOVE START KEY** before dismounting from the tractor.
16. **NEVER** stand between tractor and disc when hitching.
17. **PROVIDE** a first aid kit. Treat all scratches, cuts, etc. with proper antiseptic immediately.
18. If **DECALS** become damaged or come off, they should be replaced immediately.
19. **REMEMBER** that safe operation is no accident.

## ON HIGHWAY OPERATION

1. Use the **SLOW-MOVING** vehicle emblem in daytime and approved warning lights at night, or during other periods of poor visibility, to prevent highway accidents.
2. **COMPLY** with Local highway regulation concerning moving machinery on highways.
3. **MAINTAIN** complete control of machines at all times when traveling on the highway
4. Due to the width of implement, **USE EXTRA CAUTION** on highways, far lanes and when approaching gates



## 3 POINT TANDEM DISC HARROW

**SX-N  
SXL-N  
SERIES**



**REVERSIBLE  
SUPER NARROW  
VINEYARD DISC  
3'8 TO 7'6"**

- NORMAL DISCING
  - REVERSE DISCING
  - FLAT FURROWING

- TUBULAR CONSTRUCTION FRAME
- QUICK PIN ADJUSTMENTS
- CAT I & CAT II HITCH - STANDARD-



### **DOMRIES ENTERPRISES, INC**

12281 Road 29

Madera, California 93638

Office (559) 673-9143 Fax (559) 673-4110

Visit our website @ [www.domries.com](http://www.domries.com)



## SXL-N SERIES

SEE PRICE SHEET FOR BLADE SIZE AND EDGE COMBINATIONS

MODEL	WIDE & NARROW	NO. OF BLADES		BLADE SIZE	BLADE EDGE		BLADE SPG.		GANG RODS	APPROX. WT. LBS.
		FRONT/REAR	FRONT/REAR		FRONT/REAR	FRONT/REAR				
SXL-N-2222-9	3'8" TO 4'0"	4	4	22"	S	S	9	9	1 1/8"	965
SXL-N-2322-9	4'4" TO 5'6"	5	5	22"	S	S	9	9	1 1/8"	1005
SXL-N-3322-9	4'10" TO 6'0"	6	6	22"	S	S	9	9	1 1/8"	1060
SXL-N-3422-9	6'0" TO 7'6"	7	7	22"	S	S	9	9	1 1/8"	1120

## SX-N SERIES

SEE PRICE SHEET FOR BLADE SIZE AND EDGE COMBINATIONS

MODEL	WIDE & NARROW	NO. OF BLADES		BLADE SIZE	BLADE EDGE		BLADE SPG.		GANG RODS	APPROX. WT. LBS.
		FRONT/REAR	FRONT/REAR		FRONT/REAR	FRONT/REAR				
SXL-N-2222-9	3'8" TO 4'0"	4	4	22"	S	S	9	9	1 1/2"	1130
SXL-N-2322-9	4'4" TO 5'6"	5	5	22"	S	S	9	9	1 1/2"	1190
SXL-N-3322-9	4'10" TO 6'0"	6	6	22"	S	S	9	9	1 1/2"	1250
SXL-N-3422-9	6'0" TO 7'6"	7	7	22"	S	S	9	9	1 1/2"	1330

### STANDARD FEATURES

- 1 1/2" RO 1 1/8" SQ. GANG RODS
- TRIPLE SEALED BALL BEARINGS
- BEARING WEAR GUARDS
- CAT I OR CAT II HITCH
- ADD-A-BLADE EXTENSION WASHERS
- TUBULAR FRAME CONSTRUCTION

### OPTIONS

- BLADE CLEANERS
- ADD-ABLADE EXTENSIONS
- 24" DIAMETER BLADES  
SMOOTH OR NOTCHED  
FRONT OR REAR
- DIRT DEFLECTORS
- UTILITY HITCH
- DRAG BRACKET

**DOMRIES ENTERPRISES, INC**

12281 Road 29

Madera, California 93638

Office (559) 673-9143 Fax (559) 673-4110

Visit our website @ [www.domries.com](http://www.domries.com)



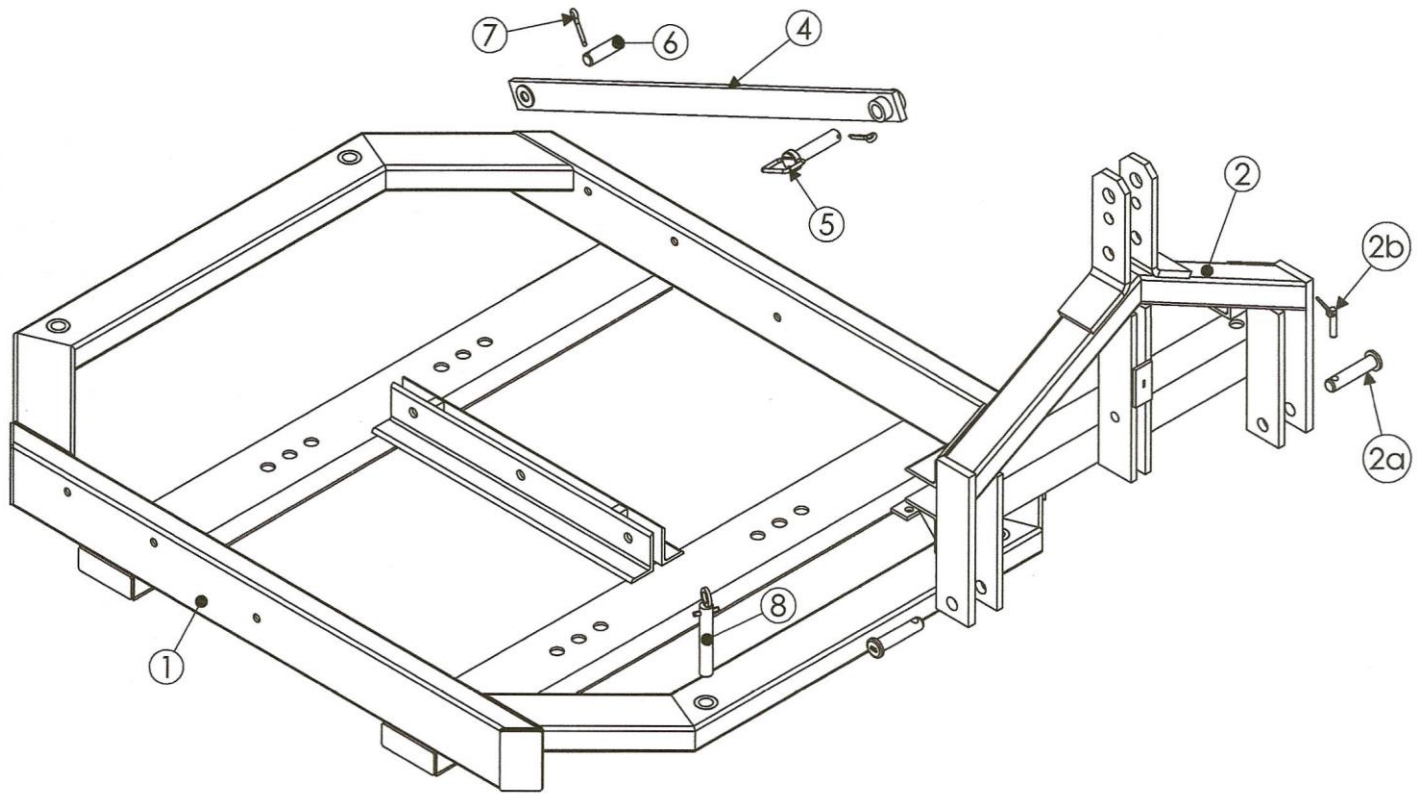

## SX-N & SXL-N MAIN FRAME ASSEMBLY

REF #	PART #	DESCRIPTION	WT/LB.
1	SX-N-01	MAIN FRAME	1050
2	SX-N-02	A FRAME-CAT I	72
2a	BLD-27	LIFT PIN-CAT I	1.0
2b	BLD-33	KLICK PIN - 7/16" DIA.	0.2
3	SX-N-23	CENTER SHANK	14.15
3a	CS58134-5	BOLT - 5/8" NC. X 1 3/4" LG. GR. 5	0.3
	LW-58	LOCK WASHER - 5/8"	0.1
	N-58	NUT - 5/8"	0.1
4	SX-N-03	BRACE - A - FRAME	11.5
5	BLD-30	PIN - A FRAME TOP	0.9
6	BLD-31	PIN - A - FRAME BOTTOM	0.2
7	HP-6	COTTER - HAIR PIN TYPE # 6	0.1
8	BLD-65	PIN - PIVOT & PULLW/PULL RING	1.0

# SXL-N

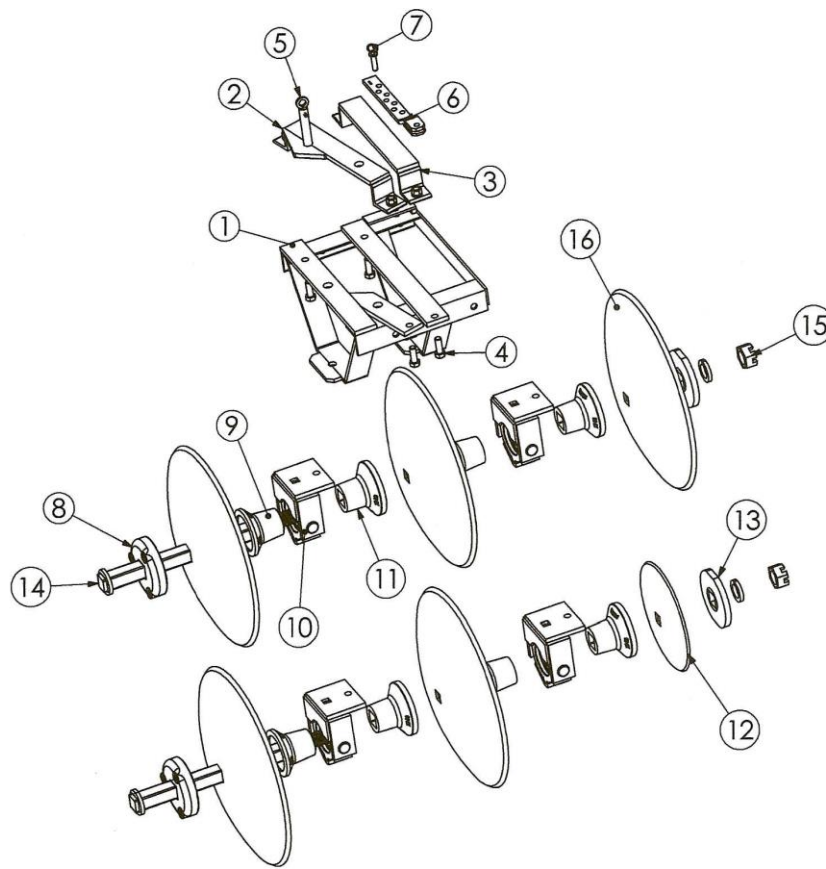

## RIGHT FRONT GANG ASSEMBLY

REF #	PART #	DESCRIPTION	WT/LB.
1	SX-N-41	GANG FRAME - 2 & 3 BLD. RIGHT FRONT	48.0
2	LTD-61	FRONT PIVOT YOKE	9.0
3	LTD-64	HOLD DOWN YOKE	8.0
4	CS58134	BOLT - 5/8" NC. X 1 3/4" LG. GR. 5	0.1
	LW58	LOCK WASHER - 5/8"	0.1
	N58	NUT - 5/8"	0.1
5	BLD-65	PIN - PIVOT W/PULL RING	N/A
6	BLD-66R	SET BAR - RIGHT HAND	N/A
7	BLD-68	PIN - SET BAR W/PULL RING	0.2
	HP3	COTTER - HAIR PIN TYPE # 3	N/A
8	JDE-19	EXT. WASHER - CONCAVE 1 1/8" SQ.	8.0
9	K-84	HALF SPOOL - CONVEX, 1 1/8" SQ.	5.7
10	K-80-A-KIT	BEARING ASSEMBLY - 1 1/8" SQ.	17.3
11	K-83	HALF SPOOL - CONCAVE, 1 1/8" SQ.	6.5
12		FILL IN BLADE - 12" (ONLY ON A 2 BLD. ASSEMBLY)	N/A
13	J-57-S	END WASHER - 1 1/8" SQ. UNIVERSAL	4.7
14	GR-3	GANG ROD - 1 1/8" SQ. 3 BLD. 9" SPC.	9.0
15	SN118	SLOTTED NUT - 1 1/8"	N/A
	LW118	LOCK WASHER - 1 1/8"	N/A
16	BLADES	DISC BLADES VARY PER SX-N MODELS	N/A

# SXL-N

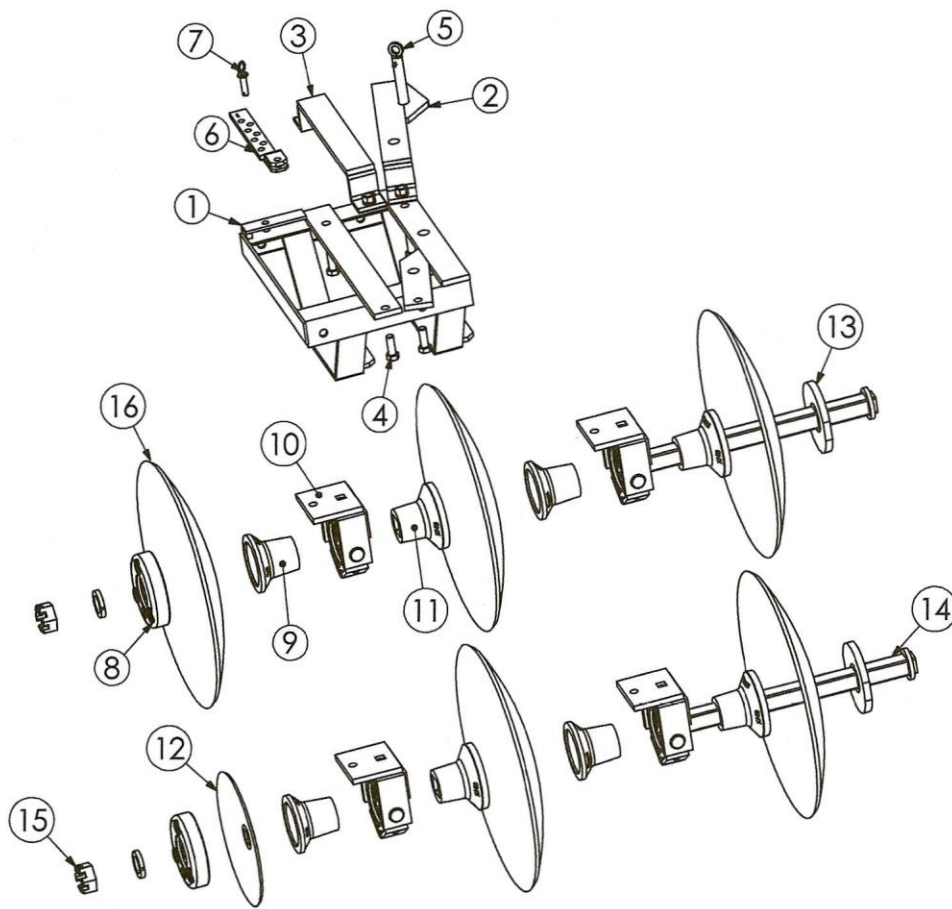

## LEFT FRONT GANG ASSEMBLY

REF #	PART #	DESCRIPTION	WT/LB.
1	SX-N-40	GANG FRAME - 2 & 3 BLD. LEFT FRONT	48.0
2	LTD-60	FRONT PIVOT YOKE-LEFT HAND	9.0
3	LTD-64	HOLD DOWN YOKE	8.0
4	CS58134	BOLT - 5/8" NC. X 1 3/4" LG. GR. 5	0.1
	LW58	LOCK WASHER - 5/8"	0.1
	N58	NUT - 5/8"	0.1
5	BLD-65	PIN - PIVOT W/PULL RING	N/A
6	BLD-66L	SET BAR - LEFT HAND	N/A
7	BLD-68	PIN - SET BAR W/PULL RING	0.2
	HP3	COTTER - HAIR PIN TYPE # 3	N/A
8	JDE-18	EXT. WASHER - CONCAVE 1 1/8" SQ.	9.0
9	K-83	HALF SPOOL - CONVEX, 1 1/8" SQ.	6.5
10	K-80-A-KIT	BEARING ASSEMBLY - 1 1/8" SQ.	17.3
11	K-84	HALF SPOOL - CONCAVE, 1 1/8" SQ.	5.7
12		FILL IN BLADE - 12" (ONLY ON A 2 BLD. ASSEMBLY)	N/A
13	J-57-S	END WASHER - 1 1/8" SQ. UNIVERSAL	4.7
14	GR-3	GANG ROD - 1 1/8" SQ. 3 BLD. 9" SPC.	9.0
15	SN118	SLOTTED NUT - 1 1/8"	N/A
	LW118	LOCK WASHER - 1 1/8"	N/A
16	BLADES	DISC BLADES VARY PER SX-N MODELS	N/A

# SXL-N

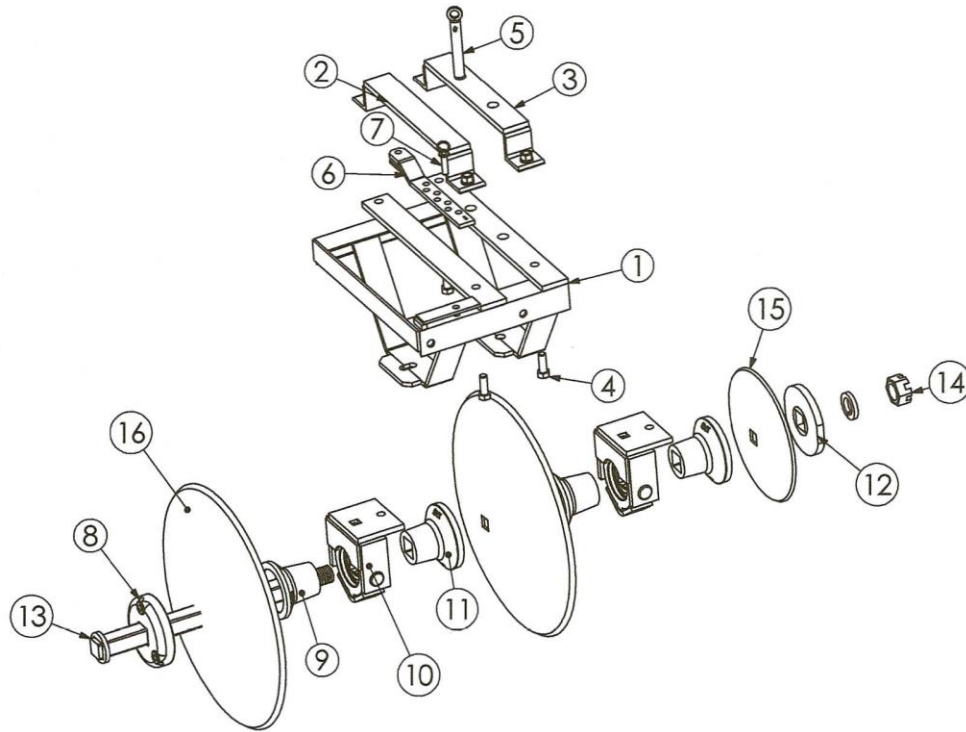

## LEFT REAR 2 BLD. GANG ASSEMBLY

REF #	PART #	DESCRIPTION	WT/LB.
1	SX-N-44	GANG FRAME - 2 BLD. LEFT REAR	N/A
2	LTD-63	YOKE PIVOT	8.5
3	LTD-64	HOLD DOWN YOKE	8.0
4	CS58134	BOLT - 5/8" NC. X 1 3/4" LG. GR. 5	0.1
	LW58	LOCK WASHER - 5/8"	0.1
	N58	NUT - 5/8"	0.1
5	BLD-65	PIN - PIVOT W/PULL RING	N/A
6	BLD-66L	SET BAR - LEFT HAND	N/A
7	BLD-68	PIN - SET BAR W/PULL RING	0.2
	HP3	COTTER - HAIR PIN TYPE # 3	N/A
8	JDE-19	EXT. WASHER - CONCAVE 1 1/8" SQ.	8.0
9	K-84	HALF SPOOL - CONVEX, 1 1/8" SQ.	5.7
10	K-80-A-KIT	BEARING ASSEMBLY - 1 1/8" SQ.	17.3
11	K-83	HALF SPOOL - CONCAVE, 1 1/8" SQ.	6.5
12	J-57S	END WASHER - 1 1/8" SQ. UNIVERSAL	4.7
13	GR-3	GANG ROD - 1 1/8" SQ. 3 BLD. 9" SPC.	N/A
14	SN118	SLOTTED NUT - 1 1/8"	N/A
	LW118	LOCK WASHER - 1 1/8"	N/A
15		FILL IN BLADE 12" DIA.	N/A
16	BLADES	DISC BLADES VARY PER SX-N MODELS	N/A

# SXL-N

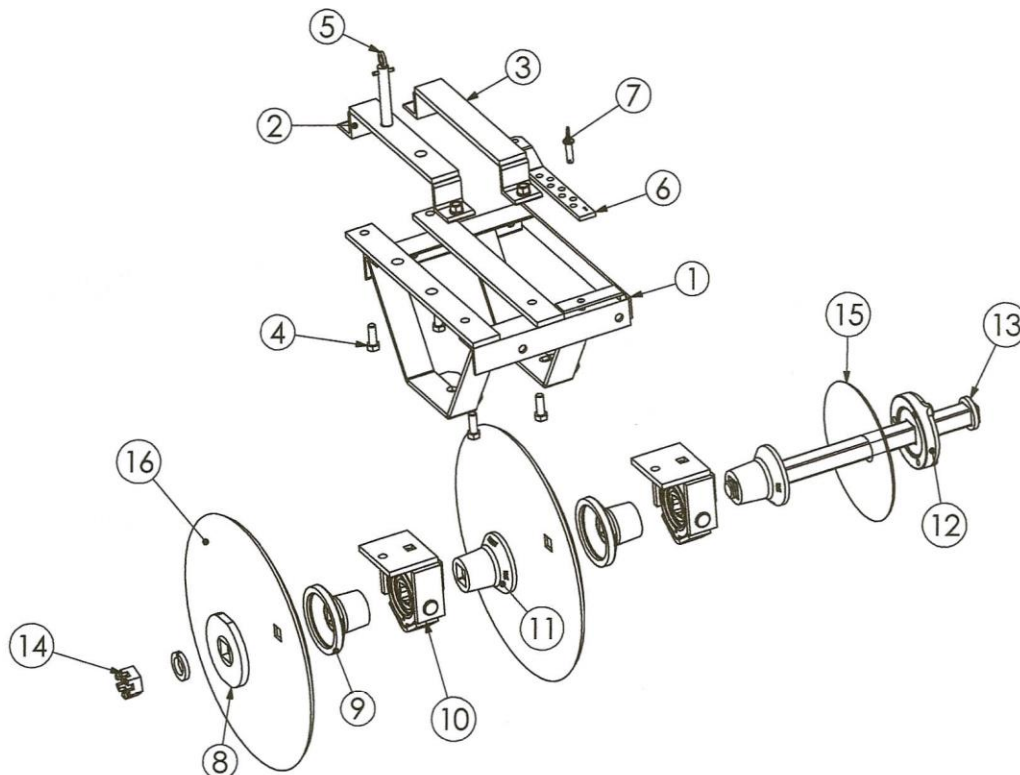

## RIGHT REAR 2 BLD GANG ASSEMBLY

REF #	PART #	DESCRIPTION	WT/LB.
1	SX-N-45	GANG FRAME - 2 BLD. RIGHT REAR	N/A
2	LTD-63	YOKE PIVOT	8.5
3	LTD-64	HOLD DOWN YOKE	8.0
4	CS58134	BOLT - 5/8" NC. X 1 3/4" LG. GR. 5	0.1
	LW58	LOCK WASHER - 5/8"	0.1
	N58	NUT - 5/8"	0.1
5	BLD-65	PIN - PIVOT W/PULL RING	N/A
6	BLD-66R	SET BAR - RIGHT HAND	N/A
7	BLD-68R	PIN - SET BAR W/PULL RING	0.2
	HP3	COTTER - HAIR PIN TYPE # 3	N/A
8	J-57-S	END WASHER - 1 1/8" SQ. UNIVERSAL.	4.7
9	K-83	HALF SPOOL - CONCAVE, 1 1/8" SQ.	6.5
10	K-80-A-KIT	BEARING ASSEMBLY - 1 1/8" SQ.	17.3
11	K-84	HALF SPOOL - CONVEX, 1 1/8" SQ.	5.7
12	JDE-19	EXT. WASHER - CONCAVE 1 1/8" SQ.	N/A
13	GR-3	GANG ROD - 1 1/8" SQ. 3 BLD. 9" SPC.	N/A
14	SN118	SLOTTED NUT - 1 1/8"	N/A
	LW118	LOCK WASHER - 1 1/8"	N/A
15		FILL IN BLADE 12" DIA.	N/A
16	BLADES	DISC BLADES VARY PER SX-N MODELS	N/A

# SXL-N

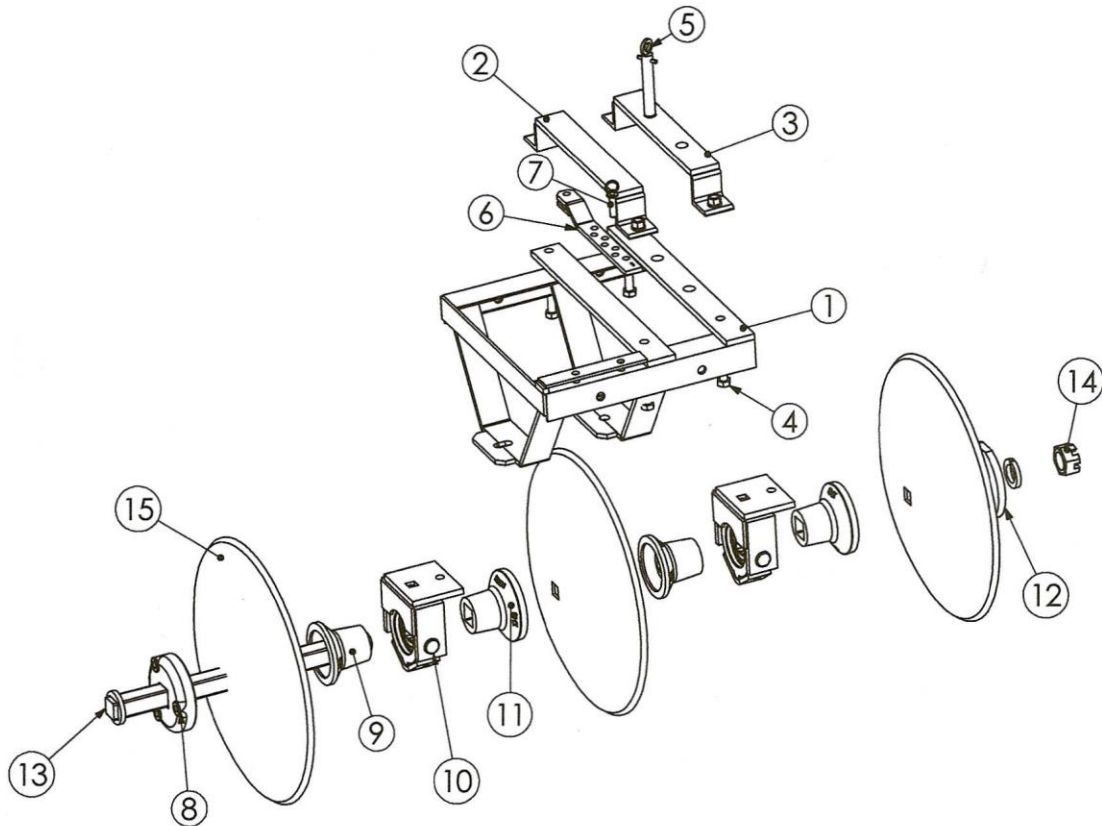

## LEFT REAR 3 BLD. GANG ASSEMBLY

REF #	PART #	DESCRIPTION	WT/LB.
1	SX-N-42	GANG FRAME - 3 BLD. LEFT REAR	N/A
2	LTD-63	YOKE PIVOT	8.5
3	LTD-64	HOLD DOWN YOKE	8.0
4	CS58134	BOLT - 5/8" NC. X 1 3/4" LG. GR. 5	0.1
	LW58	LOCK WASHER - 5/8"	0.1
	N58	NUT - 5/8"	0.1
5	BLD-65	PIN - PIVOT W/PULL RING	N/A
6	BLD-66L	SET BAR - LEFT HAND	N/A
7	BLD-68	PIN - SET BAR W/PULL RING	0.2
	HP3	COTTER - HAIR PIN TYPE # 3	N/A
8	JDE-19	EXT. WASHER - CONCAVE 1 1/8" SQ.	8.0
9	K-84	HALF SPOOL - CONVEX, 1 1/8" SQ.	5.7
10	K-80-A-KIT	BEARING ASSEMBLY - 1 1/8" SQ.	17.3
11	K-83	HALF SPOOL - CONCAVE, 1 1/8" SQ.	6.5
12	J-57-S	END WASHER - 1 1/8" SQ. UNIVERSAL	4.7
13	GR-3	GANG ROD - 1 1/8" SQ. 3 BLD.	N/A
14	SN118	SLOTTED NUT - 1 1/8"	N/A
	LW118	LOCK WASHER - 1 1/8"	N/A
15	BLADES	DISC BLADES VARY PER SX-N MODELS	N/A

# SXL-N

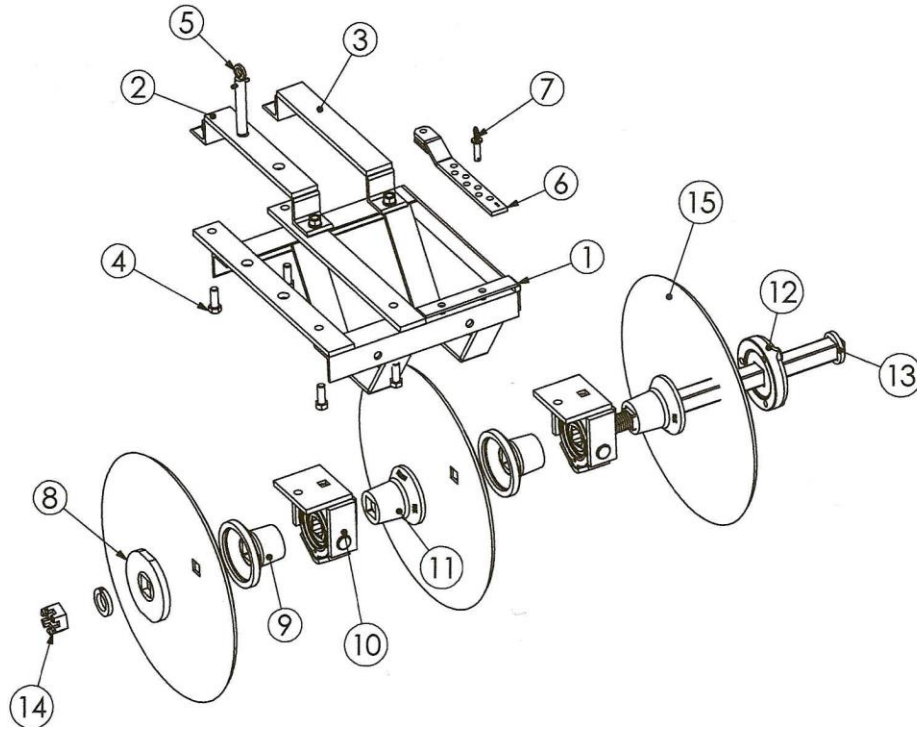

## RIGHT REAR 3 BLD. GANG ASSEMBLY

REF #	PART #	DESCRIPTION	WT/LB.
1	SX-N-43	GANG FRAME - 3 BLD. RIGHT REAR	N/A
2	LTD-63	YOKE PIVOT	8.5
3	LTD-64	HOLD DOWN YOKE	8.0
4	CS58134 LW58 N58	BOLT - 5/8" NC. X 1 3/4" LG. GR. 5 LOCK WASHER - 5/8" NUT - 5/8"	0.1 0.1 0.1
5	BLD-65	PIN - PIVOT W/PULL RING	N/A
6	BLD-66R	SET BAR - RIGHT HAND	N/A
7	BLD-68 HP3	PIN - SET BAR W/PULL RING COTTER - HAIR PIN TYPE # 3	0.2 N/A
8	J-57-S	END WASHER - 1 1/8" SQ. UNIVERSAL	4.7
9	K-83	HALF SPOOL - CONCAVE, 1 1/8" SQ.	6.5
10	K-80-A-KIT	BEARING ASSEMBLY - 1 1/8" SQ.	17.3
11	K-84	HALF SPOOL - CONVEX, 1 1/8" SQ.	5.7
12	JDE-19	EXT. WASHER - CONCAVE 1 1/8" SQ.	N/A
13	GR-3	GANG ROD - 1 1/8" SQ. 3 BLD.	N/A
14	SN118 LW118	SLOTTED NUT - 1 1/8" LOCK WASHER - 1 1/8"	N/A N/A
15	BLADES	DISC BLADES VARY PER SX-N MODELS	N/A

# SXL-N

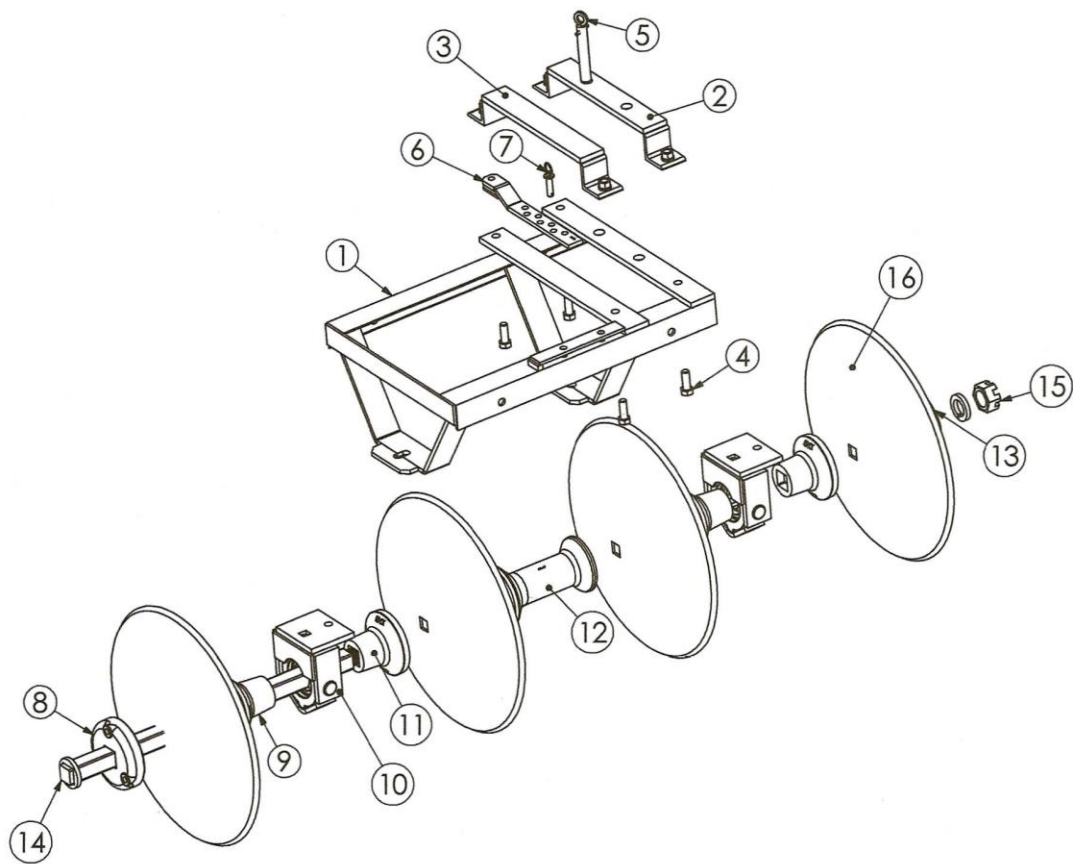

## LEFT REAR 4 BLD. GANG ASSEMBLY

REF #	PART #	DESCRIPTION	WT/LB.
1	SX-N-49	GANG FRAME - 4 BLD. LEFT REAR	N/A
2	LTD-63	YOKE PIVOT	9.6
3	LTD-64	HOLD DOWN YOKE	8.0
4	CS58134	BOLT - 5/8" NC. X 1 3/4" LG. GR. 5	0.1
	LW58	LOCK WASHER - 5/8"	0.1
	N58	NUT - 5/8"	0.1
5	BLD-65	PIN - PIVOT W/PULL RING	N/A
6	BLD-66L	SET BAR - LEFT HAND	N/A
7	BLD-68	PIN - SET BAR W/PULL RING	0.2
	HP3	COTTER - HAIR PIN TYPE # 3	N/A
8	JDE-19	EXT. WASHER - CONCAVE 1 1/8" SQ.	3.0
9	K-84	HALF SPOOL - CONVEX, 1 1/8" SQ.	5.7
10	K-80-A-KIT	BEARING ASSEMBLY - 1 1/8" SQ.	17.3
11	K-84	HALF SPOOL - CONCAVE, 1 1/8" SQ.	6.5
12	JTL-80	FULL SPOOL - 1 1/8" SQ. 9" SPACING	N/A
13	J-57-S	END WASHER - 1 1/8" SQ. UNIVERSAL	4.7
14	GR-3	GANG ROD - 1 1/8" SQ. 4 BLD.	N/A
15	SN118	SLOTTED NUT - 1 1/8"	N/A
	LW118	LOCK WASHER - 1 1/8"	N/A
16	BLADES	DISC BLADES VARY PER SX-N MODELS	N/A

# SXL-N

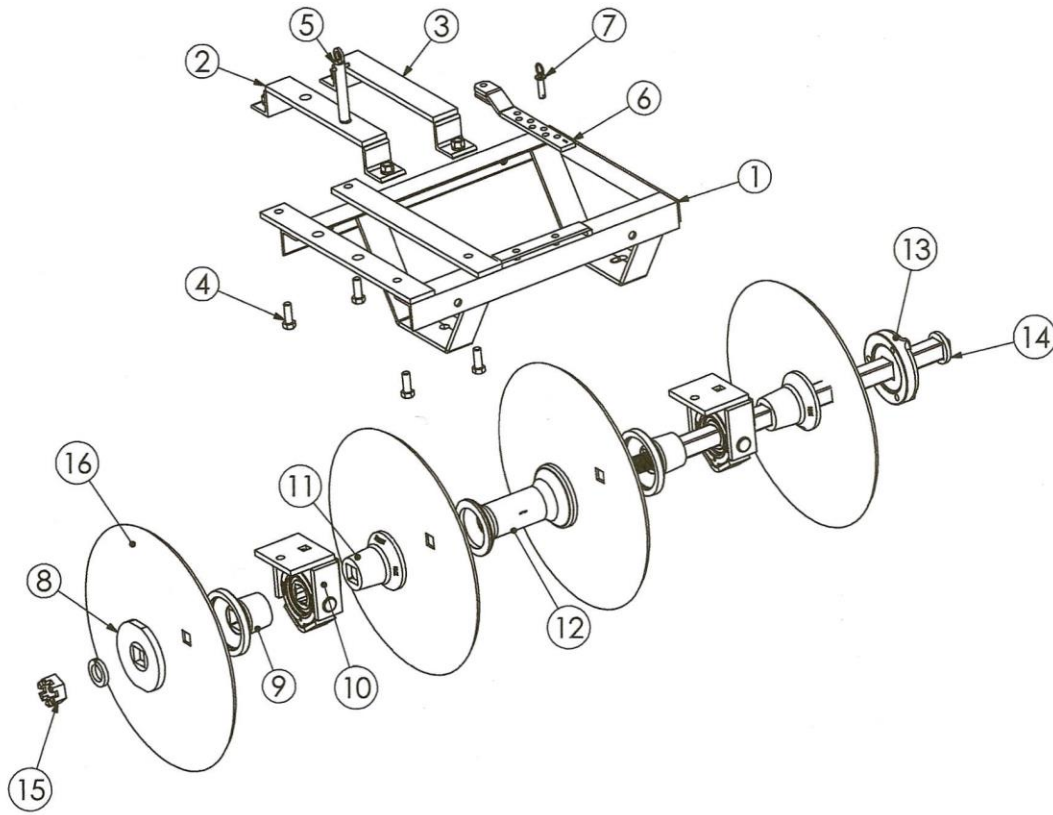

## RIGHT REAR 4 BLD. GANG ASSEMBLY

REF #	PART #	DESCRIPTION	WT/LB.
1	SX-N-48	GANG FRAME - 4 BLD. RIGHT REAR	N/A
2	LTD-63	YOKE PIVOT	8.5
3	LTD-64	HOLD DOWN YOKE	8.0
4	CS58134	BOLT - 5/8" NC. X 1 3/4" LG. GR. 5	0.1
	LW58	LOCK WASHER - 5/8"	0.1
	N58	NUT - 5/8"	0.1
5	BLD-65	PIN - PIVOT W/PULL RING	N/A
6	BLD-66R	SET BAR - RIGHT HAND	N/A
7	BLD-68	PIN - SET BAR W/PULL RING	0.2
	HP3	COTTER - HAIR PIN TYPE # 3	N/A
8	J-57-S	END WASHER - 1 1/8" SQ. UNIVERSAL	4.7
9	K-83	HALF SPOOL - CONCAVE, 1 1/8" SQ.	6.5
10	K-80-A-KIT	BEARING ASSEMBLY - 1 1/8" SQ.	17.3
11	K-84	HALF SPOOL - CONVEX, 1 1/8" SQ.	5.7
12	JTL-80	FULL SPOOL - 1 1/8" SQ. 9" SPACING	N/A
13	JDE-19	EXT. WASHER - CONCAVE 1 1/8" SQ.	N/A
14	GR-4	GANG ROD - 1 1/8" SQ. 4 BLD.	N/A
15	SN118	SLOTTED NUT - 1 1/8"	N/A
	LW118	LOCK WASHER - 1 1/8"	N/A
16	BLADES	DISC BLADES VARY PER SX-N MODELS	N/A

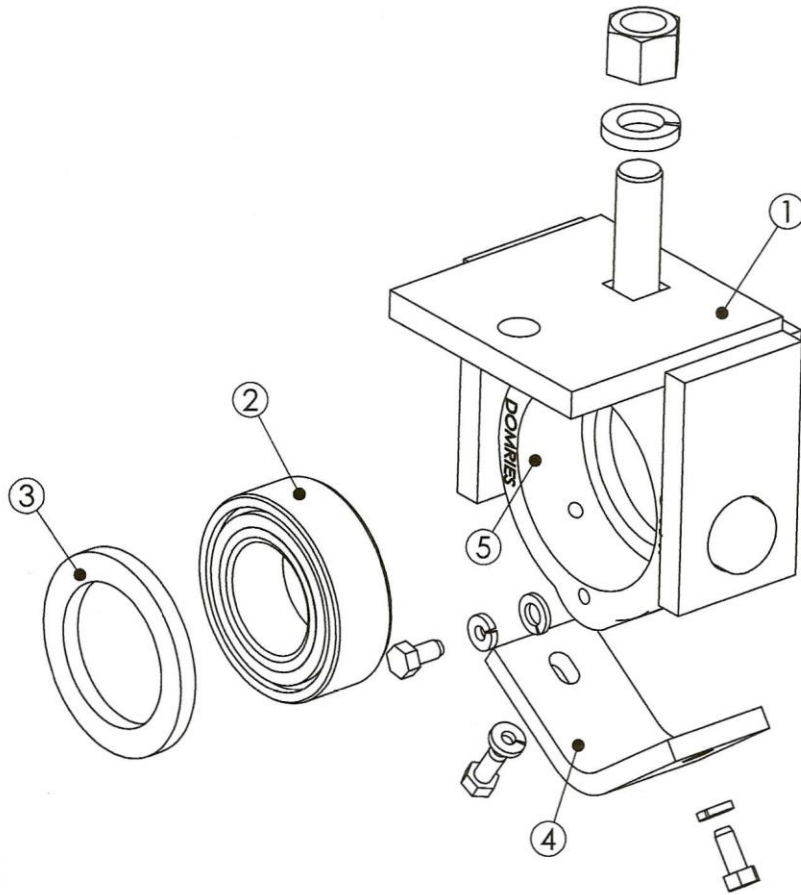

## K-80-A-KIT

REF #	PART #	DESCRIPTION	WT/LB.
1	K-81	BEARING HOUSING WELDMENT	12.0
2	K-84	BEARING	2.0
3	K-86	STOP RING	0.2
4	K-88	WEAR PLATE	2.0
5	K-81-C	BEARING HOUSING CASTING ONLY	5.8

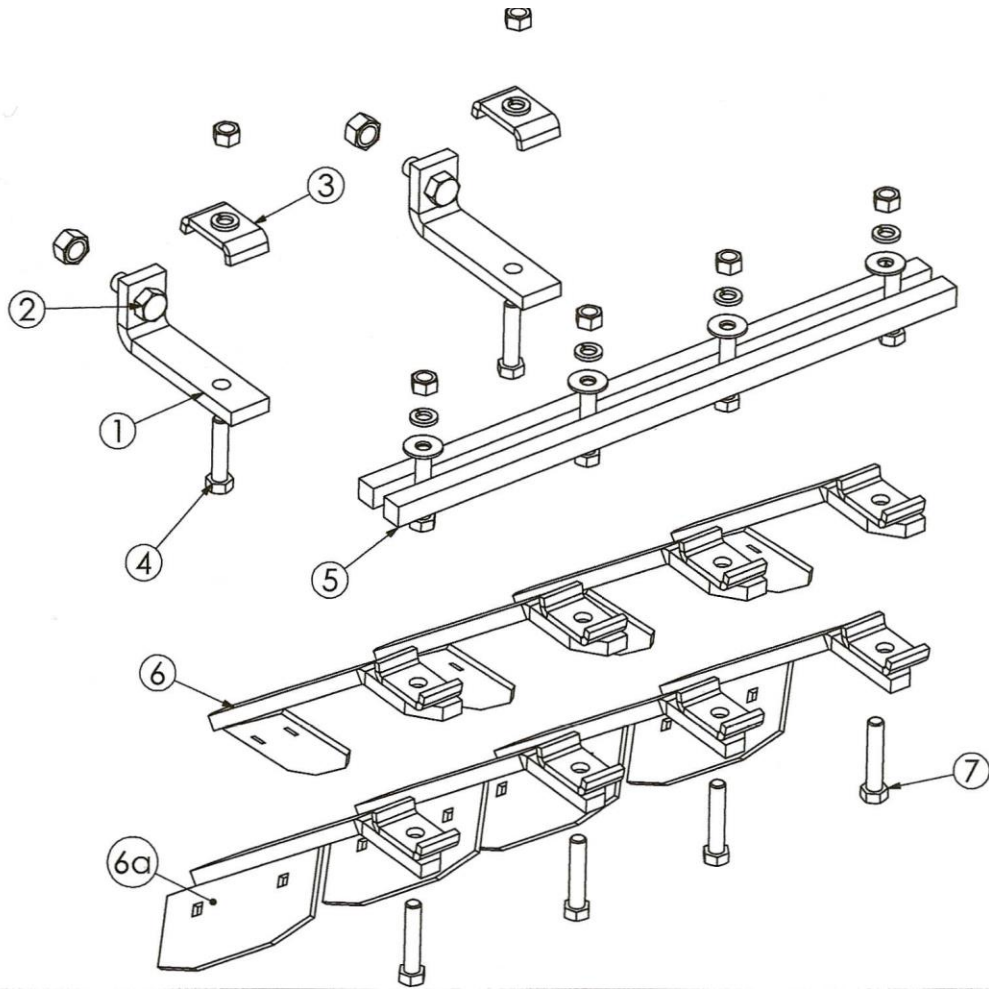

## CLEANER ASSEMBLY

REF #	PART #	DESCRIPTION	WT/LB.
1	JCP-27	BRACKET - CLEANER BAR	2.0
2	CS58112-3	BOLT - 5/8" NC. X 1 1/2" LG. GR. 5	0.3
	LW58	LOCK WASHER - 5/8"	0.1
	N58	NUT - 5/8"	0.1
3	JCP-28	CLIP - CLEANER BAR	0.3
4	CS12214-5	BOLT - 1/2" NC. X 2 1/4" LG. GR. 5	0.2
	LW12	LOCK WASHER - 1/2"	N/A
	N12	NUT - 1/2"	N/A
5	SX-N-05	CLEANER BAR - 2 BLD.	2.4
	SX-N-06	CLEANER BAR - 3 BLD.	3.5
	SX-N-07	CLEANER BAR - 4 BLD.	N/A
6	SX-N-30	ARM - CLEANER, RIGHT FRONT OR LEFT REAR	N/A
6a	SX-N-29	ARM - CLEANER, LEFT FRONT OR RIGHT REAR	N/A
7	CS12212-5	BOLT - 1/2" NC. X 2 1/2" LG. GR. 5	N/A
	FW12	FLAT WASHER - 1/2"	N/A
	LW12	LOCK WASHER - 1/2"	N/A
	N12	NUT - 1/2"	N/A

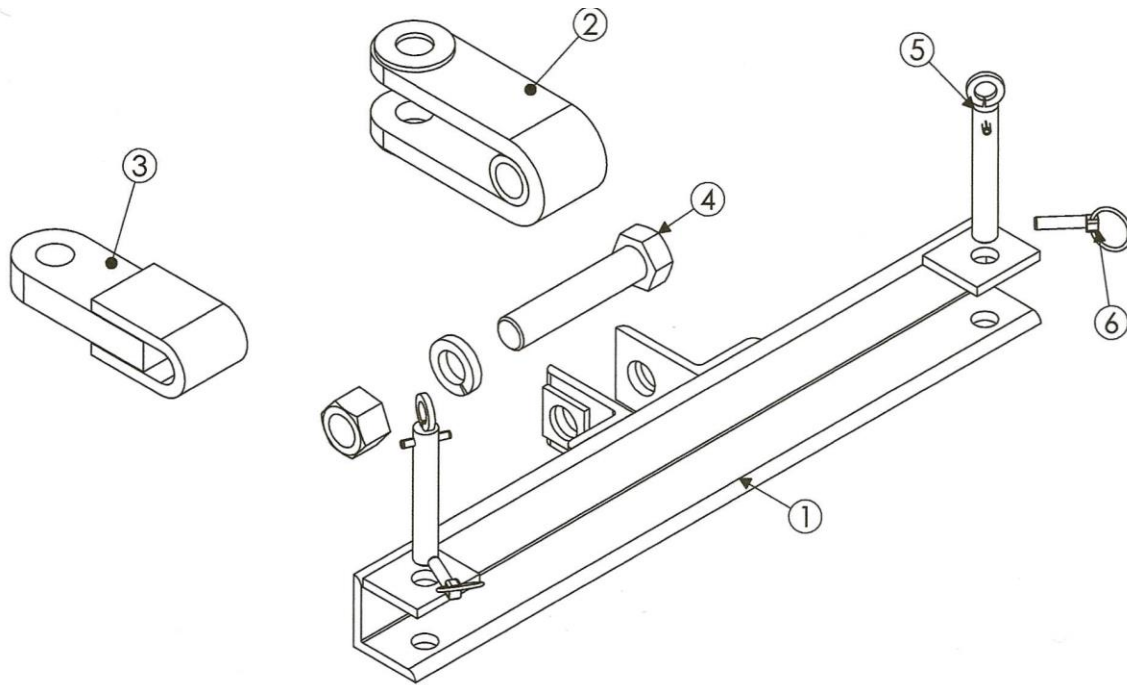

## UTILITY HITCH ASSEMBLY

REF #	PART #	DESCRIPTION	WT/LB.
1	SX-N-27	UTILITY HITCH	22.0
2	OL-134	TONGUE - CLEVIS TYPE	13.8
3	OL-135	TONGUE - SINGLE LIP	11.0
4	CS1146-5	BOLT - 1 1/4" NC. X 6" LG. GR. 5	1.0
	LW114	LOCK WASHER - 1 1/4"	0.1
	N114	NUT - 1 1/4"	0.6
5	BLD-65-H	PIN W/PULL RING & HOLE	1.0
6	BLD-33	KLICK PIN - 7/16" DIA.	0.2

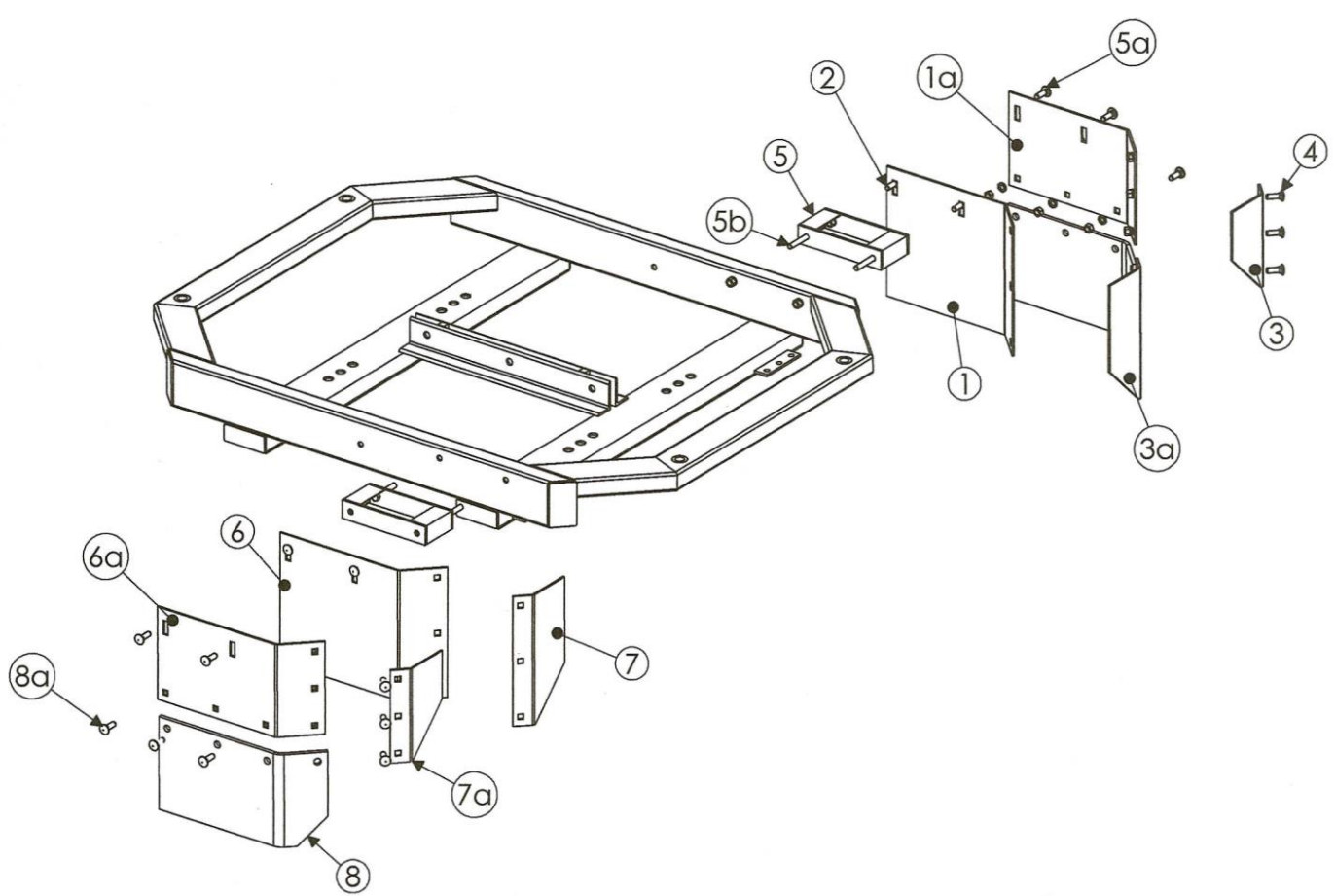

## SX-N & SXL-N DIRT SHIELD

REF #	PART #	DESCRIPTION	WT/LB.
1	SX-N-10	DIRT SHIELD-LEFT HAND	13.0
1a	SX-N-10-B	DIRT SHIELD-LEFT HAND (BELTED)	N/A
2	CB123-5	CARRIAGE BOLT - 1/2" X 3" LG. GR. 5	0.3
	LW12	LOCK WASHER - 1/2"	0.2
	N12	NUT - 1/2" NC., HEX	0.9
3	SX-N-14	DIRT SHIELD EXT. - LEFT	N/A
	SX-N-14-B	DIRT SHIELD EXT. - LEFT (BELTED)	N/A
4	CB12114-5	CARRIAGE BOLT - 1/2" NC. X 1 1/4" LG. GR. 5	0.5
	LW12	LOCK WASHER - 1/2"	0.1
	N12	NUT - 1/2" NC. HEX	0.3
5	SX-N-13	BRACKET - DIRT SHIELD (USE ON 3 BLD SET UP)	4.0
5a	CB12114-5	CARRIAGE BOLT - 1/2" NC. X 1 1/4" LG. GR. 5 (DIRT SHIELD TO BRACKET)	0.5
	LW12	LOCK WASHER - 1/2"	0.1
	N12	NUT - 1/2" NC., HEX	0.3
5b	CS123-5	BOLT - 1/2" NC. X 3" LG. GR. 5 (BRACKET TO MAIN FRAME)	0.3
	LW12	LOCK WASHER - 1/2"	0.2
	N12	NUT - 1/2" NC., HEX	0.9
6	SX-N-11	DIRT SHIELD - RIGHT	13.0
6a	SX-N-11-B	DIRT SHIELD - RIGHT (BELTED)	N/A
7	SX-N-15	DIRT SHIELD EXT. - RIGHT	4.0
7a	SX-N-15-B	DIRT SHIELD EXT. - RIGHT (BELTED)	N/A
8	SX-N-16	RUBBER BELT (BELTED DIRT SHIELD ASSY.)	N/A
8a	CB12114-5	CARRIAGE BOLT - 1/2" NC. X 1 1/4" LG. GR. 5 (BELT TO DIRT SHIELD)	N/A
	LW12	LOCK WASHER - 1/2"	N/A
	N12	NUT - 1/2" NC., HEX	N/A

3	TTR-100	MULCHER - 14 3/4" LG.	21.25
3a	TTR-101	MULCHER - 7 3/8" LG.	14.2
4	CCSN-01	SPACER - 1 3/4" LG.	N/A
5	CCSN-02	SPACER - 9/16" LG.	N/A
6	CC-27	WEAR PLATE - CLOD CRUSHER	N/A
7	RPO-466-I-KIT	BEARING ASSEMBLY - 1 1/2" X SQ., THREAD TYPE	N/A
7a	RPO-80	BEARING HOUSING - 1 1/2" SQ. THREAD TYPE	6.7
7b	RPO-103 I	BEARING - GNG. 1 1/2" NR IMPORT	3.2
7c	RPO-99	RETAINING RING	.01
8	RPO-93	SHOULDER BOLT	0.4
9	SX-N-24	MULCHER HOLDER	N/A
10	CS14-5	BOLT - 1" NC. X 4" LG .GR. 5	N/A
	LN	LOCK NUT - 1"	N/A
11	CB12312-5	CARRIAGE BOLT - 1/2" NC. X 3 1/2" LG. GR. 5	N/A
	LW12	LOCK WASHER - 1/2"	N/A
	N12	NUT - 1/2"	N/A
12	SX-N-27	SHIMS - MULCHER HOLDER	N/A



# DOMRIES ENTERPRISES, INC.

12281 Road 29, Madera CA 93638 • (P) 559-673-9143 • (F) 559-673-4110

---

---

## WARRANTY

---

---

Under this warranty Domries' obligation shall be limited to repairing or replacing, free of charge to the original purchaser, any defective part. Each part is subject to our assessment, and must show evidence of a manufacturing defect.

Product will be returned to Domries, routed through the dealer from whom the purchase was made. The cost of the repair or replacement shall not be higher than the purchase price of the product, excluding tax, shipping, and installation charges.

A claim for warranty must be made with a Domries Warranty Form with a work order number. An authorized work order number is **REQUIRED** prior to any field/repair work to be done by Domries.

### RETURN GOODS

Domries reserves the right of requiring the prepaid return of any parts claimed to be defective. However, **NO** parts shall be returned **without** Domries warranty form with a work order number. Goods shall be returned to such location as shall be designated by Domries.

Domries will at its discretion, either repair, replace, or freight outbound product from Domries factory. Domries will inspect all parts for defectiveness in materials and/or workmanship. Wear and tear that is determined to be defective, are subject to an adjustment based upon useful life.

### REPAIR

Domries will not accept any charges other than its direct Dealer shop labor costs and parts required to repair such parts and/or workmanship at the Dealers place of business. The **WARRANTY** specifically excludes any charges for delivery, transportation, and/or shipping costs.

If the dealer is requested by the customer to travel or haul the machine to its shop or repair shop for the purpose of performing a warranty obligation or free inspection, it would be for the customer's convenience, and the cost of such a trip is to be paid by the customer. Any arrangement whereby the Dealer agrees to absorb all or a part of the cost is to be made **SOLELY** between the Dealer and the Customer (to be considered a courtesy to the customer by their Dealer).

### LIMITED WARRANTY

Outside purchased equipment and accessories (not of Domries manufacture) are warranted only to the extent of the original manufacturer's warranty to Domries. Examples of limited items include, Hydraulic cylinders and hoses, Bearings, Disc Blades, Wheels, Tires, Tubes, and Seals.

### NO WARRANTY

1. New product that has been subjected to operation in excess of recommended capacities, misused, negligence, lack of maintenance, an accident or have been **altered/repared in any manner not authorized by Domries**.

2. Sharp turns while machine/cutting parts are in the ground void warranty, with the exception of a drag disc.

Domries shall in no event be responsible for any delay or any other consequential or indirect damage in connection with fulfilling any obligation under this WARRANTY.

Domries reserves the right to make change at any time in designs, materials and/or specifications of its product without becoming liable or obligated in any way to make similar changes in previously manufactured products.

This **WARRANTY IS IN LIEU OF ALL OTHER WARRANTIES COVERING DOMRIES PRODUCTS** and no other warranties expressed or implied are made or authorized by Domries Enterprises, Inc.

**DEALER/SALESMAN:** \_\_\_\_\_ **DATE:** \_\_\_\_\_

**DOMRIES REP.:** \_\_\_\_\_ **DATE:** \_\_\_\_\_