

# **MODEL BTO SERIES II**

**A SUPER  
OFFSET**

**10'7"**

**TO**

**14'4"**

**SPLIT AXEL**

**LOW**

**PROFILE**

**DUAL TIRES**

**PARTS  
AND  
OPERATOR  
MANUAL**

**Domries Enterprises, Inc**

**12281 Rd 29**

**Madera, California 93638**

**Phone (559) 673-9143**

**Fax (559) 673-4110**

**Visit our Web-Site at**

**[www.domriesentinc.com](http://www.domriesentinc.com)**



## ATTENTION! BECOME ALERT!

### YOUR SAFETY IS INVOLVED!

This Symbol is used to call your attention to safety precautions. That should be followed by the operator to avoid accidents. When you see this – Heed Its Warning.

Many hours of lost time and much suffering is caused by the failure to practice simple safety rules.

1. **READ** this manual carefully to acquaint your – self with the Disk Harrow. Opening unfamiliar equipment can cause accidents.
2. **Lower Implement** if possible, when adjusting maintenance work; otherwise **BLOCKS IT SECURELY** at a workable height.
3. **When Implement** and tractor is parked always lower disk to the ground and place a **FLAG OR OTHER WARNING DEVICE** on each corner as someone could run or bump into the implement.
4. Implement should be **DETACHED ONLY** in an area where Children **DO NOT PLAY**.
5. **DO NOT** wear loose fitting clothing that could catch on various parts.
6. Machinery should be **OPERATED ONLY** by those who are **RESPONSIBLE AND DELEGATED** to do so.
7. **ONLY ONE PERSON** – the operator – should be permitted on the tractor when implement is in operation, he should be thoroughly familiar with tractor and implement.
8. **MAKE CERTAIN** that everyone is clear before starting tractor and implement combination.
9. **BEFORE WORKING** under the any hydraulically controlled unit **MAKE SURE** it is **SECURELY BLOCKED**.
10. The **RATE OF SPEED** on hillsides or curves should be regulated so there is no danger of tipping.
11. **DO NOT** drive too close to the edge of a ditch or creek.
12. **REDUCE SPEED** when transporting unit to avoid bouncing and momentary loss of steer ability.
13. **MAKE CERTAIN** tractor is equipped with sufficient front-end weight to counter-balance the plow weight and maintain stability of front of tractor
14. **DO NOT** attempt to operate tractor and implement unless you are in the driver seat.
15. **ALWAYS** place transmission in **PARK or NEUTRAL, LOCK BRAKES, STOP ENGINE AND REMOVE START KEY** before dismounting from the tractor.
16. **NEVER** stand between tractor and disc when hitching.
17. **PROVIDE** a first aid kit. Treat all scratches, cuts, etc. with proper antiseptic immediately.
18. If **DECALS** become damaged or come off, they should be replaced immediately.
19. **REMEMBER** that safe operation is no accident.

## ON HIGHWAY OPERATION

1. Use the **SLOW-MOVING** vehicle emblem in daytime and approved warning lights at night, or during other periods of poor visibility, to prevent highway accidents.
2. **COMPLY** with Local highway regulation concerning moving machinery on highways.
3. **MAINTAIN** complete control of machines at all times when traveling on the highway
4. Due to the width of implement, **USE EXTRA CAUTION** on highways, far lanes and when approaching gates

**Domries Enterprises, Inc.**

12281 Road 29  
Madera, CA 93637



**Phone (559) 673-9143**

**Fax (559) 673-4110**

**www.domreisentinc.com**

## **WARRANTY**

Domries warrant's all products of its manufacture to be free of defects in material and workmanship under normal usage and maintenance for the period of one year from the date of delivery to the original purchaser.

### RETURN GOODS

Domries shall have the option of requiring the prepaid return of any parts claimed defective, however, no parts shall be returned without Domries warranty form with good authorized number. Goods shall be returned to such location as shall be designed by Domries.

Domries will at its option, either repair or replace, F.O.B. Domries factory. Such parts as appear to Domries upon inspection, to have been defective in materials and/or workmanship. Wearing parts that are determined to be defective are subject to an adjustment based upon useful life.

### REPAIRS

Any field or repairs must have the authorized repair number from Domries before any work is done. Claim for warranty must be made with a Domries warranty form and repair number.

Domries will not accept any charged other than its direct Dealer shop labor costs and part required to remedy such parts and/or workmanship at its Dealer place of business. The WARRANTY specifically excludes any charges for delivery, transportation, and/or shipping cost.

If the dealer is requested by the customer to travel or haul the machine to his shop or repair shop for the purpose of performing a warranty obligation or free inspection, it would be for the customers' convenience, and the cost of such a trip is to be paid by the customer. Any arrangement whereby the Dealer agrees to absorb all or a part of the cost is to be made between the Dealer and the customer. To be considered a courtesy to the Customer by their Dealer.

### LIMITED WARRANTY

Outside purchase equipment and accessories (not of Domries manufacture) are warranted only to the extent of the original manufacturer's warranty to Domries.

Item Limited - Hydraulic cylinders and hose - Bearings - Disc Blades - Wheals - Tires - Tubes - Seals.

No Warranty shall be paid by Domries before the part or parts and labor have been paid to Domries by the manufacturer. Domries shall then compensate the dealer or customer.

### NO WARRANTY

(1) New product that has been subjected to operation in excess in recommended capacities, misused, negligence, lack of maintenance or accident or have been altered or repaired in any manner not authorized by Domries.

(2) Sharp turns while machine is ground void warranty, with the exception of a drag disc.

Domries shall in no event be responsible for any delay or any other consequential or indirect damage in connection with fulfilling any obligation under this WARRANTY.

Domries reserves the right to make changes at any time in designs, materials and/or specifications of its product without becoming liable or obligated in any way to make similar changes in previously manufactured products.

This WARRANTY IS IN LIEU OF ALL OTHER WARRANTIES COVERING DOMRIES PRODUCTS and no other Warranties express or implied are made or authorized by Domries Enterprises, Inc.

This WARRANTY BECAME EFFECTIVE with shipments made on or after August 1st 1998

# IMPORTANT! PLEASE READ!

## TO OUR CUSTOMER – USER’S RESPONSIBILITY- WARRANTY

### TO OUR CUSTOMER

The following pages and illustrations are printed to help supply you with the knowledge to better operate and service your new DOMRIES equipment.

We are proud to have you as a customer and feel you will be proud to be a DOMRIES owner.

Any piece of equipment needs and must have a certain amount of service and maintenance to keep it in top running condition. We have attempted to cover all the adjustments required to fit most conditions; however, there may be times special care must be taken to fit a condition.

**Study this operator’s manual carefully and become acquainted with all the adjustments and operating procedures before attempting to operate your new equipment.** Remember, it is a machine and has been designed and tested to do an efficient job in most operating conditions and will perform in relation to the service it receives.

If special attention is required for some conditions, ask your DOMRIES dealer; his Parts and Service Organization will be glad to help and answer any question on operation and service of your new machine.

### ATTENTION! BECOME ALERT!

### YOUR SAFETY IS INVOLVED

This symbol is used to call your attention to safety precautions that should be followed by the operator to avoid accidents. When you see this symbol – Heed Its Warning.

### USER’S RESPONSIBILITY

It is the responsibility of the user to read the Operator’s Manual and understand the safe and correct operating procedures as pertains to the operation of the product, and to lubricate and maintain the product according to the maintenance schedule in the Operator’s Manual.

The user is responsible for inspecting his machine and for having parts repaired or replaced when continued use of the product would cause damage or excessive wear to the other parts. It is the user’s responsibility to deliver his machine to a DOMRIES dealer, for service or replacement of defective parts which are covered by the standard warranty. When requesting warranty service, you present your copy of delivery record.

**MODEL#** \_\_\_\_\_

**SERIAL#** \_\_\_\_\_



# DOMRIES ENTERPRISES, INC.

12281 Road 29, Madera CA 93638 • (P) 559-673-9143 • (F) 559-673-4110

---

---

## WARRANTY

---

---

Under this warranty Domries' obligation shall be limited to repairing or replacing, free of charge to the original purchaser, any defective part. Each part is subject to our assessment, and must show evidence of a manufacturing defect.

Product will be returned to Domries, routed through the dealer from whom the purchase was made. The cost of the repair or replacement shall not be higher than the purchase price of the product, excluding tax, shipping, and installation charges.

A claim for warranty must be made with a Domries Warranty Form with a work order number.

An authorized work order number is **REQUIRED** prior to any field/repair work to be done by Domries.

### RETURN GOODS

Domries reserves the right of requiring the prepaid return of any parts claimed to be defective. However, **NO** parts shall be returned **without** Domries warranty form with a work order number. Goods shall be returned to such location as shall be designated by Domries.

Domries will at its discretion, either repair, replace, or freight outbound product from Domries factory. Domries will inspect all parts for defectiveness in materials and/or workmanship. Wear and tear that is determined to be defective, are subject to an adjustment based upon useful life.

### REPAIR

Domries will not accept any charges other than its direct Dealer shop labor costs and parts required to repair such parts and/or workmanship at the Dealers place of business. The **WARRANTY** specifically excludes any charges for delivery, transportation, and/or shipping costs.

If the dealer is requested by the customer to travel or haul the machine to its shop or repair shop for the purpose of performing a warranty obligation or free inspection, it would be for the customer's convenience, and the cost of such a trip is to be paid by the customer. Any arrangement whereby the Dealer agrees to absorb all or a part of the cost is to be made **SOLELY** between the Dealer and the Customer (to be considered a courtesy to the customer by their Dealer).

### LIMITED WARRANTY

Outside purchased equipment and accessories (not of Domries manufacture) are warranted only to the extent of the original manufacturer's warranty to Domries. Examples of limited items include, Hydraulic cylinders and hoses, Bearings, Disc Blades, Wheels, Tires, Tubes, and Seals.

**NO WARRANTY**

1. New product that has been subjected to operation in excess of recommended capacities, misused, negligence, lack of maintenance, an accident or have been ***altered/repared in any manner not authorized by Domries.***
2. Sharp turns while machine/cutting parts are in the ground void warranty, with the exception of a drag disc.

Domries shall in no event be responsible for any delay or any other consequential or indirect damage in connection with fulfilling any obligation under this WARRANTY.

Domries reserves the right to make change at any time in designs, materials and/or specifications of its product without becoming liable or obligated in any way to make similar changes in previously manufactured products.

This ***WARRANTY IS IN LIEU OF ALL OTHER WARRANTIES COVERING DOMRIES PRODUCTS*** and no other warranties expressed or implied are made or authorized by Domries Enterprises, Inc.

**DEALER/SALESMAN:** \_\_\_\_\_ **DATE:** \_\_\_\_\_

**DOMRIES REP.:** \_\_\_\_\_ **DATE:** \_\_\_\_\_

**BTO  
SERIES II**



**WHEEL TYPE  
OFFSET WHEEL DISC**

**A SUPER OFFSET  
10'7 TO 15'0"**



**LOW PROFILE DUAL TIRES**



**DOMRIES ENTERPRISES, INC**

12281 Road 29

Madera, California 93638

Office (559) 673-9143 Fax (559) 673-4110

Visit our website @ [www.domries.com](http://www.domries.com)



# BTO II DISC FEATURES



DEPTH CONTROL

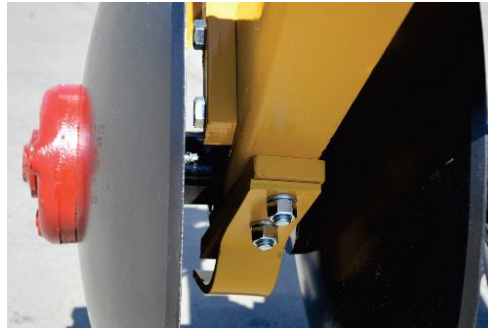

HEAVY DUTY WEAR PLATE AND  
BLADE EXTENSION IS STANDARD



SINGLE TONGUE STANDARD  
DOUBLE IS OPTIONAL

## BTO II DISC MODEL

MODEL	A.S.A.E.		NO. OF BLADES	BLADE SIZE	BLADE EDGE		NO. OF BLADES		WT.LBS.
	WIDTH	OF CUT			FRONT	REAR	FRONT	REAR	
BTO-20-2840	10'7"		28	24	SM	SM	14	14	5019
BTO-20-2860	10'8"		28	26	SM	SM	14	14	5161
BTO-20-3040	11'4"		30	24	SM	SM	15	15	5122
BTO-20-3060	11'5"		30	26	SM	SM	15	15	5274
BTO-20-3240	12'1"		32	24	SM	SM	16	16	5225
BTO-20-3260	12'2"		32	26	SM	SM	16	16	5387
BTO-20-3440	12'10"		34	24	SM	SM	17	17	5435
BTO-20-3460	12'11"		34	26	SM	SM	17	17	5607
BTO-20-3640	13'6"		36	24	SM	SM	18	18	5538
BTO-20-3660	13'7"		36	26	SM	SM	18	18	5721
BTO-20-3840	14'3"		38	24	SM	SM	19	19	5641
BTO-20-3860	14'4"		38	26	SM	SM	19	19	5834

SEE PRICE SHEET FOR NOTCHED OR SMOOTH BLADE COMBINATIONS

### DOMRIES ENTERPRISES, INC

12281 Road 29

Madera, California 93638

Office (559) 673-9143 Fax (559) 673-4110

Visit our website @ [www.domries.com](http://www.domries.com)



Domries reserves the right to make changes and/or improvements in design and construction of

Ref #	Part #	Main Frame Assembly	Wt./lb	List Price
1.	BT-20-1	Male Frame-BTO Series II	735	
2.	J-116	Axle-Block, 2 1/2" d	4.8	
3.	JJ-90	Hyd. Cylinder-3"dx12" Stroke	30	
4.	RPO-136	U' Bolt-1"d	4.9	
5.	LW1	Spring Lock Washer	0.1	
6.	N1	Nut - 1"nc, Hex	0.1	
7.	N114	Nut - 1 1/4nc, Hex	0.6	
8.	CS13-5	Bolt - 1"ncx3"lg	0.9	
9.	CS11412-5	Bolt - 1 1/4ncx12lg	7	
10.	W1029	Flat Washer	0.3	
11.	W1011	Wrench 7/8"	2.6	

MODEL - BTO-2

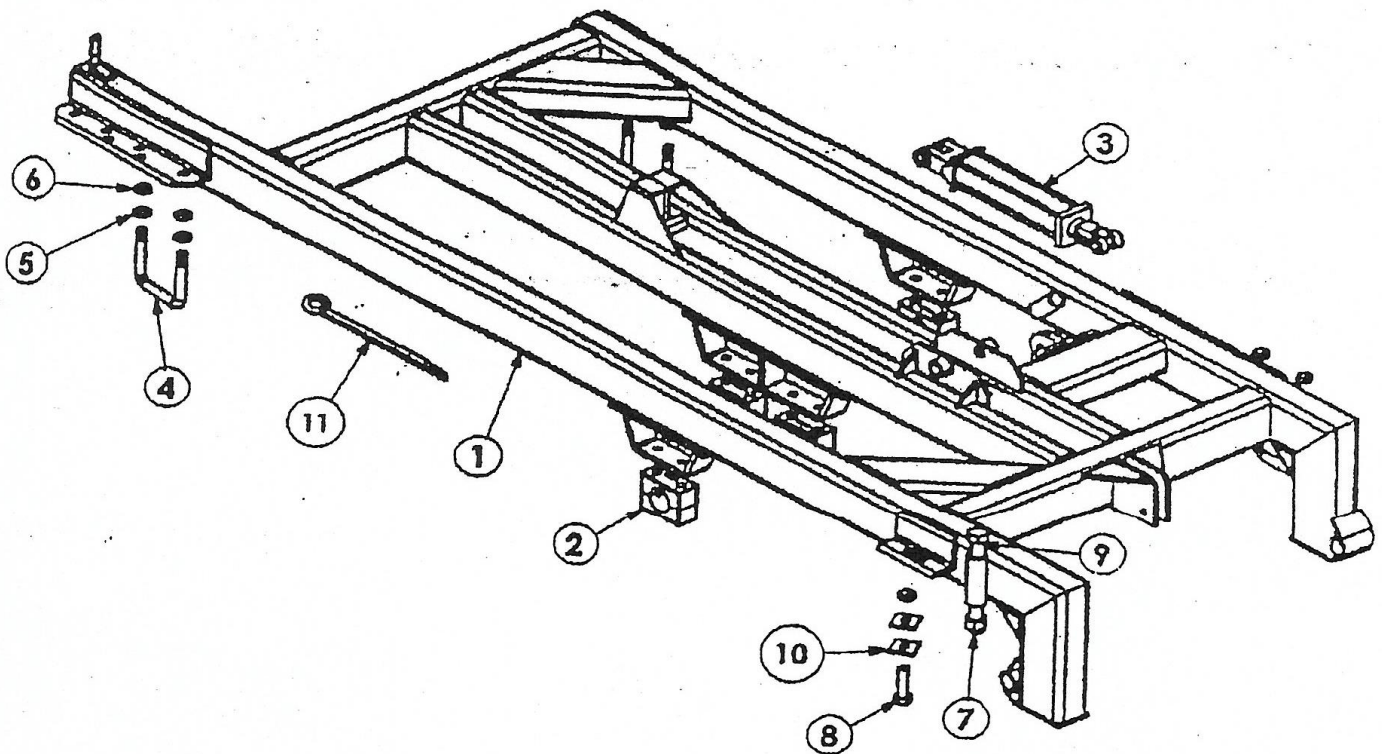

**DOMRIES ENTERPRISES INC.**

12281 Road 29

Madera, California 93638

Phone (559) 673-9143 Fax (559) 673-4110

Ref #	Part #	Split Axle Assembly	Wt./lb	List Price
1.	BT-20-01A	Crank Assy-Split Type Axle	24.5	
2.	BT-10-05	Strap Swivel	5.3	
3.	BT-20-07	Axle Half Assy-RH, Series II	116	
4.	BT-20-08	Axle Half Assy-LH, Series II	172	
5.	BT-20-63	Set Bar Depth Control	23.5	
6.	BT-20-02	Swivel Nut-Threaded	1.6	
7.	BT-20-03	Swivel Nut-Plain	1.5	
8.	BT-20-06	Bushing-Crank Swivel	0.1	
9.	OH-126	Set Bar Pin	0.6	
10.	OH-148	Pin Rocker	0.7	

MODEL - BTO-2

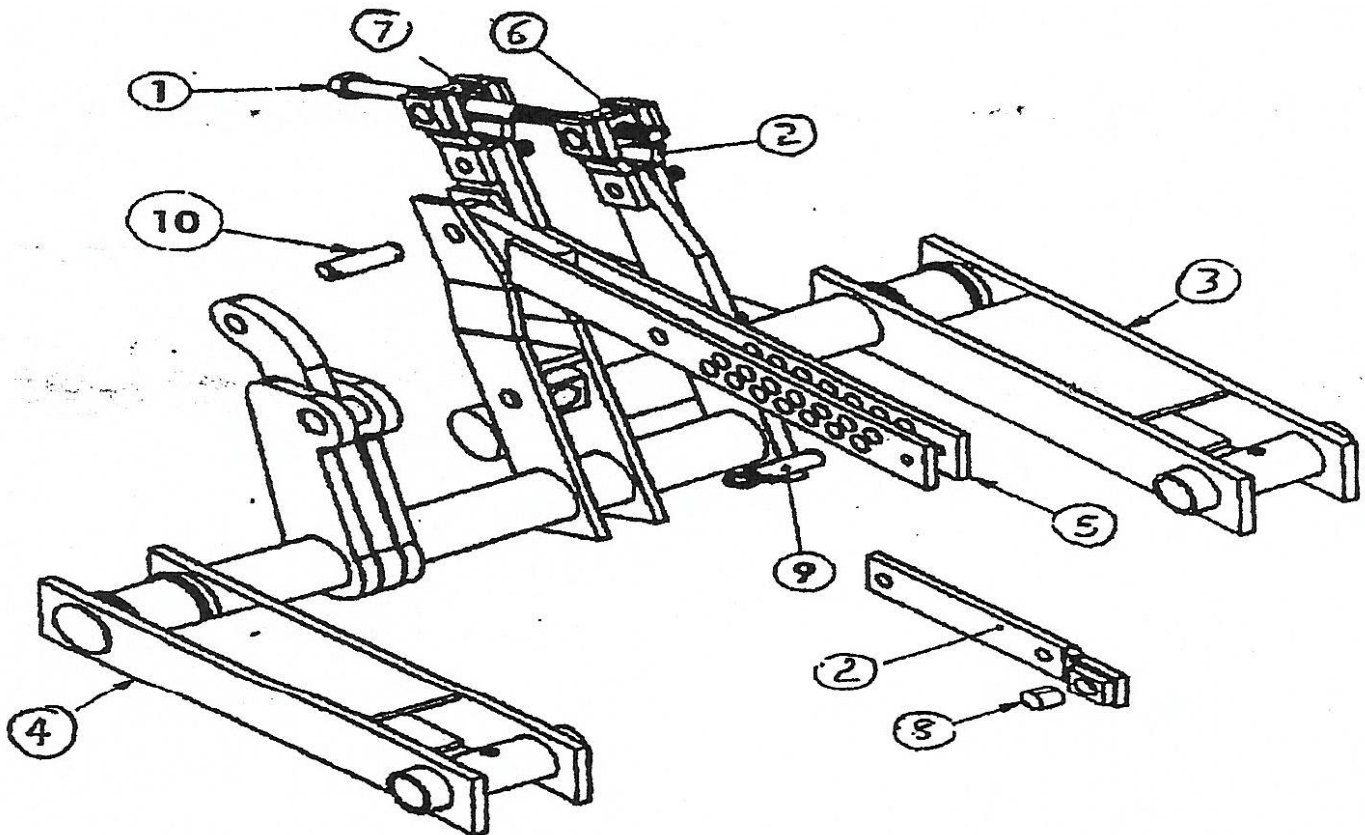

DOMRIES ENTERPRISES INC.

12281 Road 29

Madera, California 93638

Phone (559) 673-9143 Fax (559) 673-4110

Ref #	Part #	Hitch Assembly	Wt./lb	List Price
1.	BLD33	Klick Pin - 7/16 dia	0.2	
2.	BT-20-10	Angle Set Hitch Pin	1	
3.	BT-20-11	Outer Tube-DB Angle Set	25.6	
4.	BT-20-12	Inner Tube-DB Angle Set	8.8	
5.	BT-20-13	Draw Bar BTO Series II Offset	117	
6.	BT-20-14	Cross Member Hitch	102	
7.	BT-20-15	Hitch Pin BTO Series II	6	
8.	OL-133	Tongue-Pin	3.1	
9.	OH-134	Clevis Type Tongue	18.3	
10.	OH-135	Single Lip Tongue	19	
11.	OH-136	Hose Guide	7	
12.	OH-136C	Clamping-Strap	0.9	

**MODEL - BTO-2**

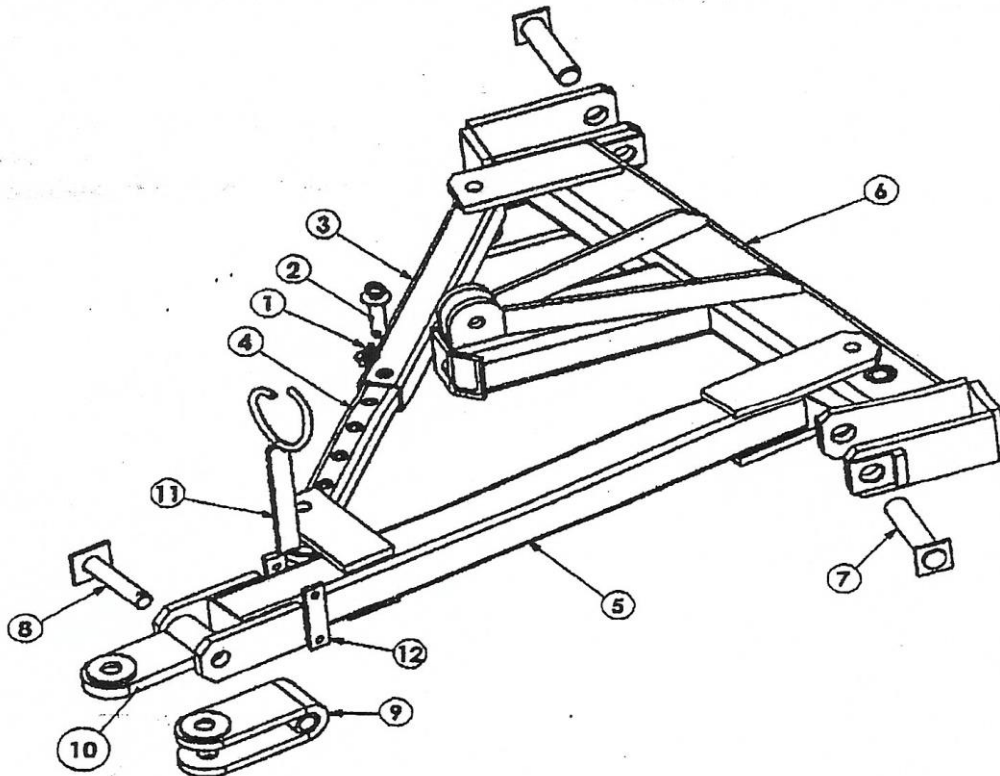

**DOMRIES ENTERPRISES INC.**

12281 Road 29

Madera, California 93638

Phone (559) 673-9143 Fax (559) 673-4110

Ref #	Part #	Leveling Rod Assembly	Wt./lb	List Price
1.	BT-20-08-16	Swivel, Leveling Rod	1	
2.	BT-20-26	Link-Leveling	21	
3.	BT-20-27	Hammer-Leveling	19	
4.	BT-20-29	Rocker Weldment (Swivel)	13.9	
5.	BT-20-52	Spring Guide-Double	1.9	
6.	BT-20-53	Spring Guide-Single	1.9	
7.	BT-20-149	Leveling Rod	21.5	
8.	OH-150	Spring Leveling	5.8	
9.	JJ-60	Clip Lock, Drag Link	0.2	
10.	OH-145	Cross Pin	2.5	
11.	OH-148	Rocker Pin	0.7	
12.	ON-9	Rod-Turnbuckle, RH Thd	4.2	
13.	ON-10	Body-Turnbuckle	7.2	
14.	ON-11	Rod-Turnbuckle, LH Thd	4.2	
15.	SN114	Slotted Nut - 1 1/4nc, Hex	0.5	
16.	CP143	Cotter Pin		

MODEL - BTO-2

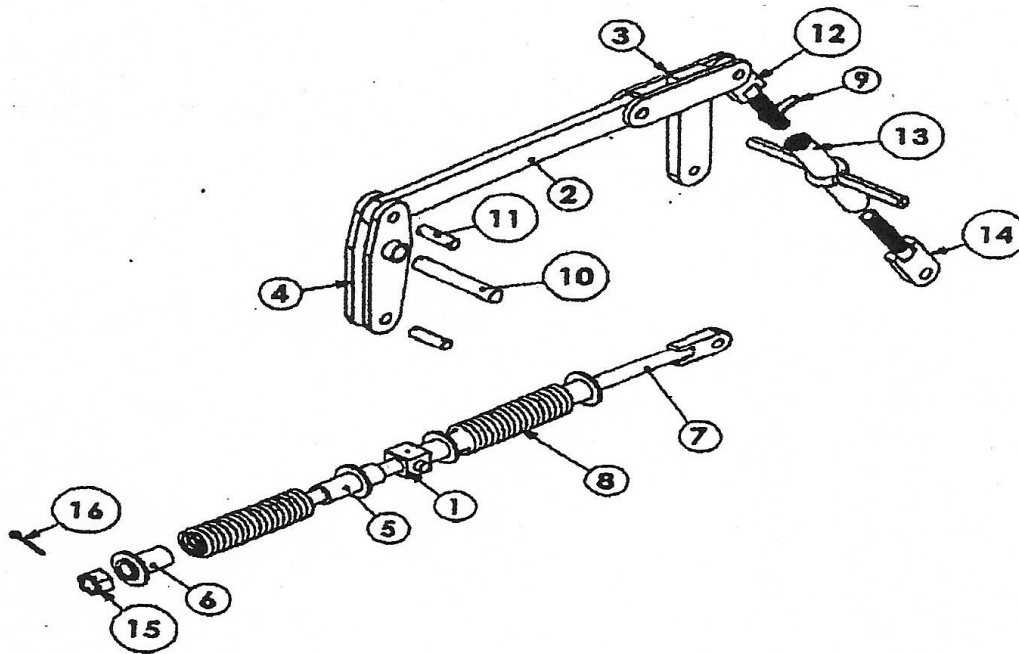

DOMRIES ENTERPRISES INC.

12281 Road 29

Madera, California 93638

Phone (559) 673-9143 Fax (559) 673-4110

Ref #	Part #	Gang Assembly	Wt./lb	List Price
1.	XGR-4	Gang Rod - 1 1/2sq, 4 Blade, 9"	20	
	XGR-5	Gang Rod - 1 1/2sq, 5 Blade, 9"	26	
	XGR-6	Gang Rod - 1 1/2sq, 6 Blade, 9"	32	
	XGR-7	Gang Rod - 1 1/2sq, 7 Blade, 9"	38	
	XGR-8EL	Gang Rod - 1 1/2sq, 8 Blade, 9"	44.2	
	XGR-9EL	Gang Rod - 1 1/2sq, 9 Blade, 9"	50.2	
2.	JXE-18	Ext. Washer - CVX 1 1/2sq	9	
3.	JXE-19	Ext. Washer - CCV 1 1/2sq	8	
4.	RPO-129D-Kit	Brg. Assy. 1 1/2"sq. 9"	11.4	
5.	RPO-104	Full Spool 1 1/2"sq. 9"	19.4	
6.	RPO-113	Half Spool - CVX, 1 1/2sq	10.7	
7.	RPO-114	Half Spool - CCV, 1 1/2sq	5.8	
8.	RPO-117	Mtg. Strap-Flat, Brg.	3.7	
9.	RPO-133	Offset Bearing Guard	7.5	
10.	LW112	Lock Washer- Spring	0.2	
11.	SN112	Slotted Nut 1 1/2"nc	0.8	
12.	CP143	Cotter Pin		
13.	X-98	End Washer Universal 1/2"sq	4.7	
<b>RPO-129D-Kit</b>				
14.	RPO-81	Bearing Housing - 1 1/2sq Ear Type	6.4	
15.	RPO-103D	Gang Bearing Assy 1 1/2sq	3.5	
16.	RPO-99	Retaining Ring	0.1	

**MODEL - BTO-2**

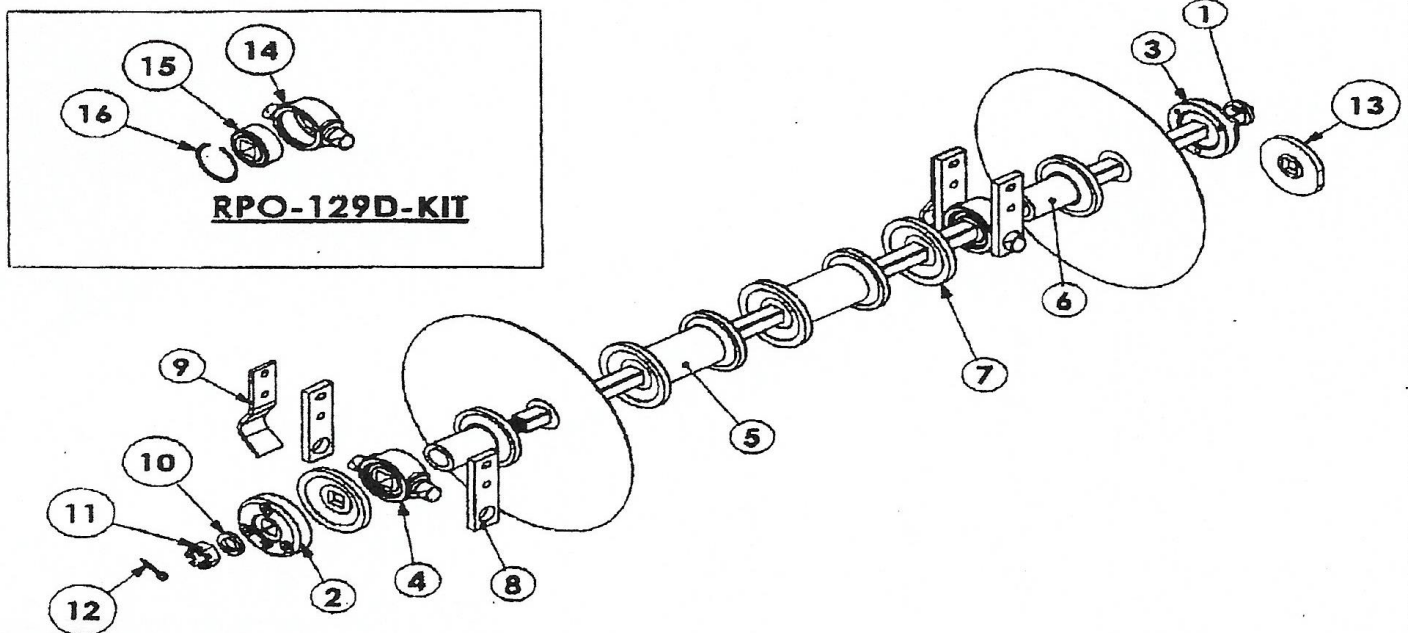

Ref #	Part #	Cleaner Bar Assembly	Wt./lb	List Price
1.	BT-308	Scraper-Bar	13.4	
	BT-309	Scraper-Bar	15.3	
	BT-310	Scraper-Bar	17.2	
	BT-311	Scraper-Bar	19.2	
	BT-312	Scraper-Bar	21.2	
	BT-313	Scraper-Bar	23.2	
	BT-314	Scraper-Bar	24.2	
2.	RPO-115	Scraper-Blade	2.5	
3.	RPO-116+clip	Scraper-Arm	3	
4.	RPO-120	Scraper-Clip Arm	0.4	
5.	CS12434-5	Bolt-1/2ncx4 3/4lg	0.3	
6.	CS12312-5	Bolt-01-2ncx3 1/2lg	0.3	
7.	LW12	Lock Washer-Spring	0.1	
8.	N12	Nut-1/2nc, Hex	0.1	
9.				

MODEL - BTO-2

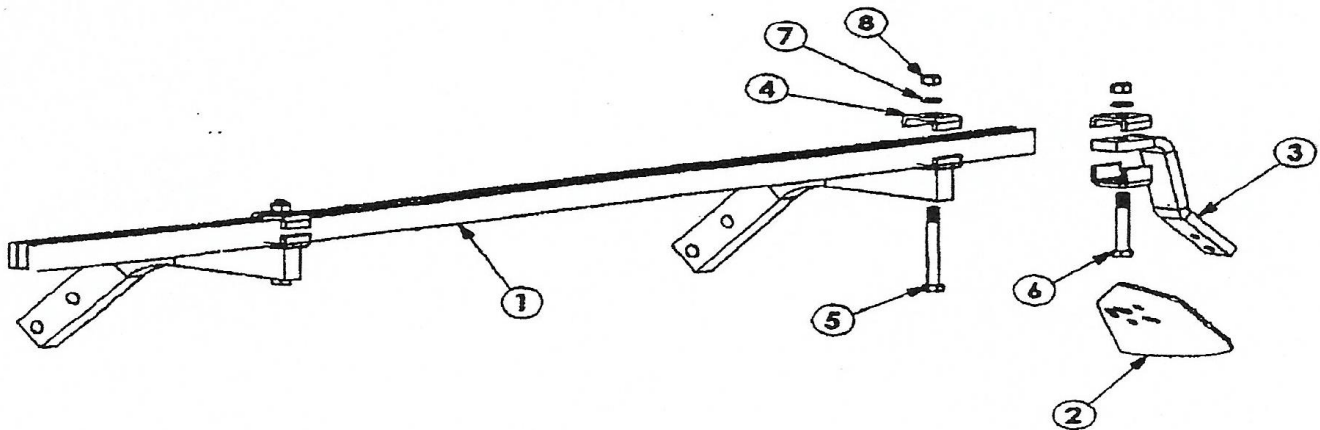

Ref #	Part #	Gang Frame	Wt./lb	List Price
1.	BT-20-28F	Gang Frame-14 Blade, Front	301	
	BT-20-30F	Gang Frame-15 Blade, Front	318	
	BT-20-32F	Gang Frame-16 Blade, Front	335	
	BT-20-34F	Gang Frame-17 Blade, Front	352	
	BT-20-36F	Gang Frame-18 Blade, Front	369	
	BT-20-38F	Gang Frame-19 Blade, Front	386	
2.	BT-20-28R	Gang Frame-14 Blade, Rear	290	
	BT-20-30R	Gang Frame-15 Blade, Rear	307	
	BT-20-32R	Gang Frame-16 Blade, Rear	324	
	BT-20-34R	Gang Frame-17 Blade, Rear	341	
	BT-20-36R	Gang Frame-18 Blade, Rear	358	
	BT-20-38R	Gang Frame-19 Blade, Rear	375	

MODEL - BTO-2

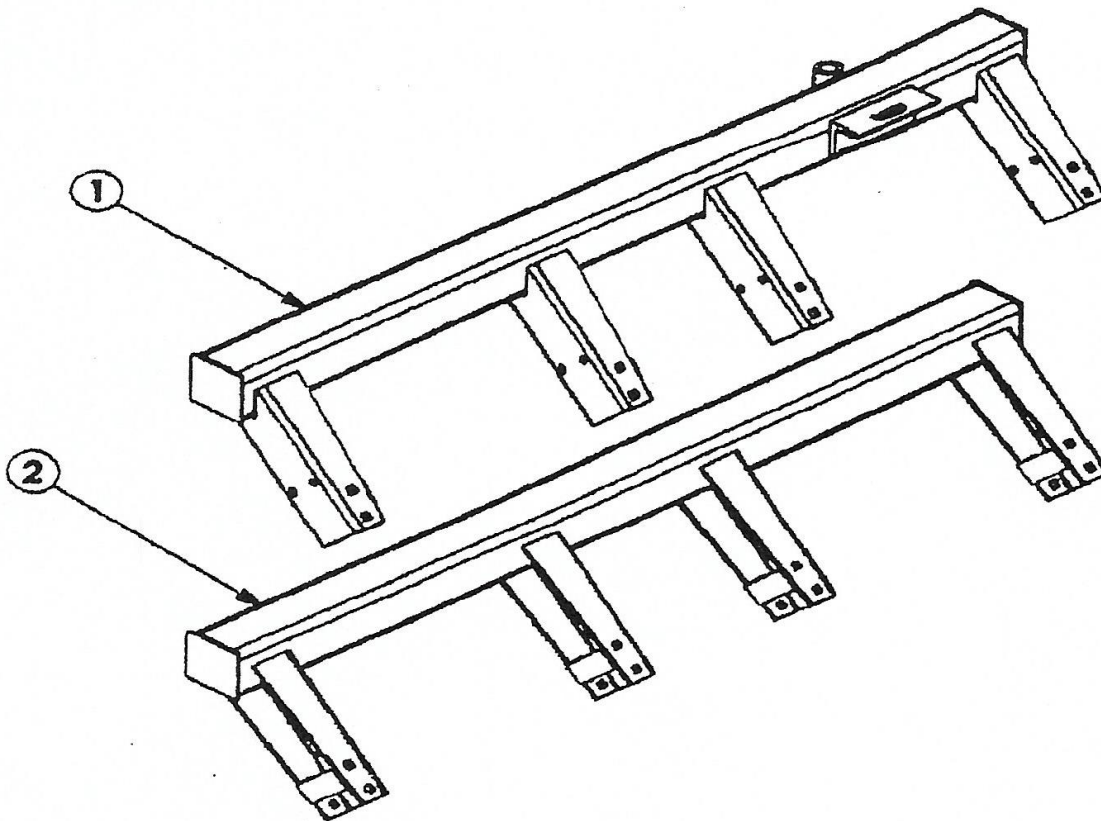

Ref #	Part #	Spindle Assembly	Wt./lb	List Price
1.	DSH-302	Hub	10	
2.	DSH-303	Bearing Cup, Outer	0.1	
3.	DSH-304	Bearing Cone, Outer	0.3	
4.	DSH-305	Bearing Cup, Inner	0.2	
5.	DSH-306	Bearing Cone, Inner	0.4	
6.	DSH-307	Inner Seal	0.1	
7.	DSH-308	Outer Seal	0.1	
8.	DSH-309	Tubing Sleeve	0.3	
9.	DSH-310	Clamp Assy	0.3	
10.	BT-20-312	Slip in Spindle	9	
11.	DSH-313	Slotted Nut	0.1	
12.	DSH-314	Spindle Washer	0.01	
13.	DSH-316	Dust Cap	0.2	
14.	DSH-318	Lug Bolt-(1/2"nfx1"Long)	0.1	
15.	JJ-19	Wheel-15x6m 6 (1/2)	23	
16.	JJ-20	Tire-7.60-15, Rib 6 Ply	24	

MODEL - BTO-2

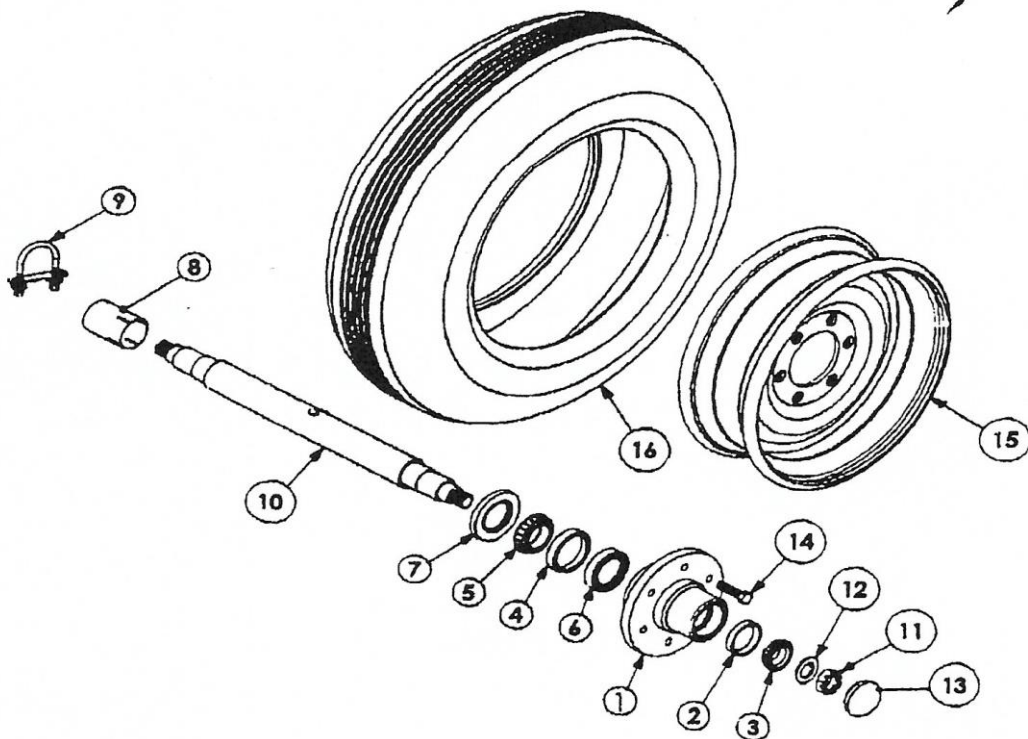

Ref #	Part #	Extension Spool Assembly	Wt./lb	List Price
1.	JXE-17	Ext. Spool-(Blade Pulls in) 9"	11	
2.	JXE-20	Cap-Ext. Spool, Universal, 1 1/2	3	
3.	CS12112-5	Bolt-1/2ncx1 1/2lg, GR 5	0.1	
4.	LW12	Lock Washer-Spring	0.1	
5.	N12	Nut-1/2nc, Hex	0.1	
6.	CS58112-5	Bolt-5/8ncx1 1/2lg, GR 5	0.3	
7.	LW58	Lock Washer-Spring	0.1	
8.	EXB-24	Ext. Blade-24"d Sld Edge, 1 1/2sq	25	
	EXV-24N	Ext. Blade-24"d Notched, 1 1/2sq	23	
	EXB-26	Ext. Blade-26"dia, Solid Edge	31.5	

MODEL - BTO-2

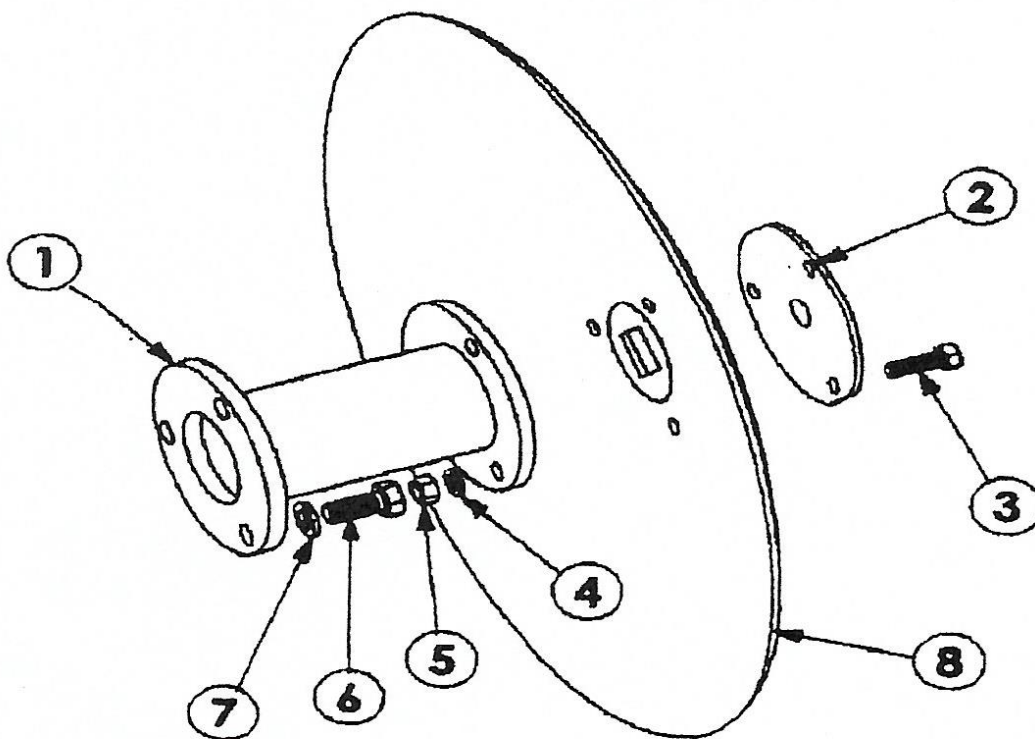

Ref #	Part #	Front Dirt Shield Assembly	Wt./lb	List Price
1.	BT-DS-F-01	Bottom Bracket Front		
4.	BT-DS-F-02	Top Bracket Front		
5.	BT-DS-F-08	Dirt Shield Front		
<b>Rear Dirt Shield Assembly</b>				
2.	BT-DS-R-01	Bottom Bracket Rear		
3.	BT-DS-R-02	Top Bracket Rear		
6.	BT-DS-R-05	Dirt Shield Rear		

**MODEL- BTO-2**

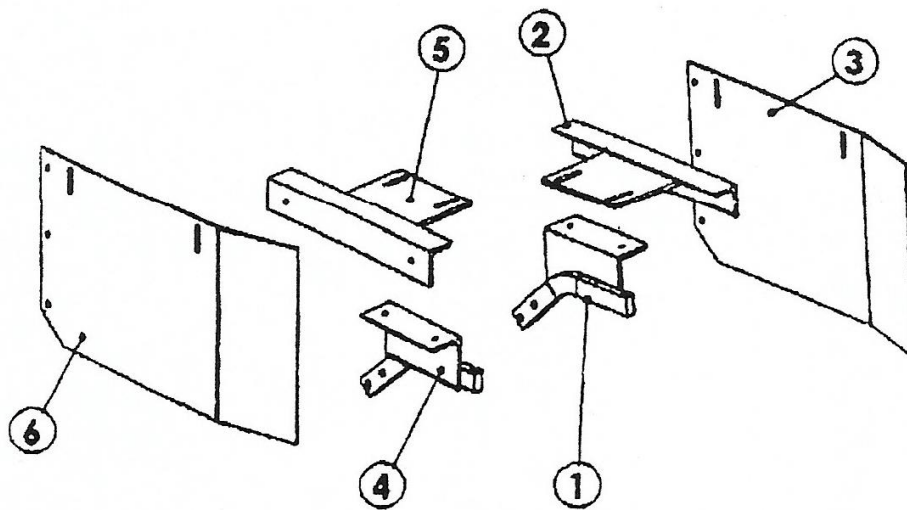

Ref #	Part #	Utility Hitch	Wt./lb	List Price
1.	BT-20-UH-C	Utility Hitch Clovise	111	
5.	BT-20-UH-S	Utility Hitch Single	104	

